

CERAMICHE

GRAZIA

SINCE 1970

General Book

General Book

Since 1970

Mission

Nata nel 1970 da un gruppo di imprenditori con grande esperienza nel settore, fin dalle origini si è data come mission quella di realizzare collezioni ceramiche di alto livello, privilegiando la qualità artigianale, unitamente alla ricerca di un risultato estetico originale. La terracotta smaltata, una delle più importanti scoperte della storia dell'umanità, rappresenta ancora il filo conduttore delle realizzazioni dell'azienda, molto lontano dalla imitazione dei materiali naturali offerte dal settore. Le soluzioni proposte, sia in bicottura che in gres porcellanato, continuano a mantenere il sapore della ceramica vera, come espressione dell'antica tradizione della trasformazione di argilla e pigmenti al fuoco del forno.

Le varie linee di prodotto offerte da Ceramiche Grazia, sia da pavimento che da rivestimento, sono proposte in molteplici colori e le varianti decorative sono corredate di pezzi speciali, in modo da consentire al cliente finale la soluzione dei problemi di finitura riscontrabili durante la posa. Ciò consente di accontentare ogni esigenza di gusto e design.

Scegliendo Ceramiche Grazia ci si affida ad un'azienda di grande esperienza e di sicura qualità, in grado di offrire prodotti unici di alta gamma per ogni necessità di utilizzo. Sempre pronti ad assistere la clientela nella scelta della tipologia di materiale più adatto per il progetto e la realizzazione di ambienti da vivere.

Founded in 1970 by a group of experienced entrepreneurs, the company's mission has been from the very beginning to create high-quality ceramic collections, prioritizing artisanal quality combined with a quest for original aesthetics. Glazed terracotta, one of the most important discoveries in human history, still represents the guiding principle of the company's creations, far away from the natural materials' imitations proposed by the industry.

The solutions offered, both double-fired tiles and porcelain stoneware, continue to retain the taste of true ceramics, an expression of the ancient tradition of transforming clay and pigments inside the kiln.

The various product lines offered by Ceramiche Grazia, both for floors and walls, are available in a wide range of colors and the decorative options are complemented by special pieces, allowing the end customer to solve any finishing issues encountered during installation. This allows us to satisfy any taste and design requirements. By choosing Ceramiche Grazia, you are trusting in a company with extensive experience and guaranteed quality, capable of offering unique, high-end products for any application. We are always ready to assist customers in choosing the most suitable material for their project and the creation of living spaces.





Vision

Fuoco, acqua, aria, terra, sono i quattro elementi con i quali, secondo l'antica filosofia greca, tutte le cose esistono e coesistono. Sono ancora oggi gli elementi che caratterizzano il nostro lavoro e continueranno ad esserlo. Tramite essi si ottiene la ceramica vera, che rappresenta la nostra mission.

Pur rimanendo fedeli al nostro spirito, alla materia e alla smaltatura tradizionale, i nostri tecnici sono alla continua ricerca di soluzioni cromatiche di tendenza, ma anche alla realizzazione di formati e corredi innovativi. Il nostro obiettivo è quello di dare la possibilità a progettisti, designer e appassionati dell'arredo e della qualità di esprimere, tramite le nostre collezioni, soluzioni personalizzate, e a valorizzare gli spazi attraverso l'utilizzo della vera ceramica. Quelle che si trovano nel nostro catalogo sono solo alcune delle possibilità di ambienti che si possono ottenere con i nostri prodotti, ma le combinazioni sono in realtà limitate solo dalla propria fantasia.

I pezzi speciali che contraddistinguono le nostre collezioni arricchiscono e completano un'offerta di formati e colori che vuole soddisfare ogni gusto.

Fire, water, air and earth are the four elements with which, according to ancient Greek philosophy, all things exist and coexist. They are still characterizing our work today and will always be. Through them true ceramics, which embodies our mission, comes out.

While remaining faithful to our spirit, substance and traditional glazing, our technicians are constantly researching trendy color solutions, as well as creating innovative formats and accessories. Our goal is to empower architects, designer, and interior design enthusiasts with passion for quality to express personalized solutions through our collections and enhance spaces through the use of true ceramics. Those found in our catalog are just a few of the possible settings that can be created with our products, but the combinations can actually be limited by your own imagination.

The special pieces that distinguish our collections enrich and complete a range of formats and colors designed to satisfy every taste.

Arte antica / *Ancient art*

L'amore per la materia, per gli smalti e per la lavorazione artigianale hanno dettato ogni creazione made in Grazia, sin dalle sue origini nel 1970. Le forme più iconiche di Grazia sono nate da gessi intagliati e stampi creati direttamente dal laboratorio interno.

The love for the substance, glazes and artisanal production have characterized every creation made in Grazia, since its origins in 1970. Grazia's most iconic shapes were born from carved plasters and molds created directly by our internal laboratory.



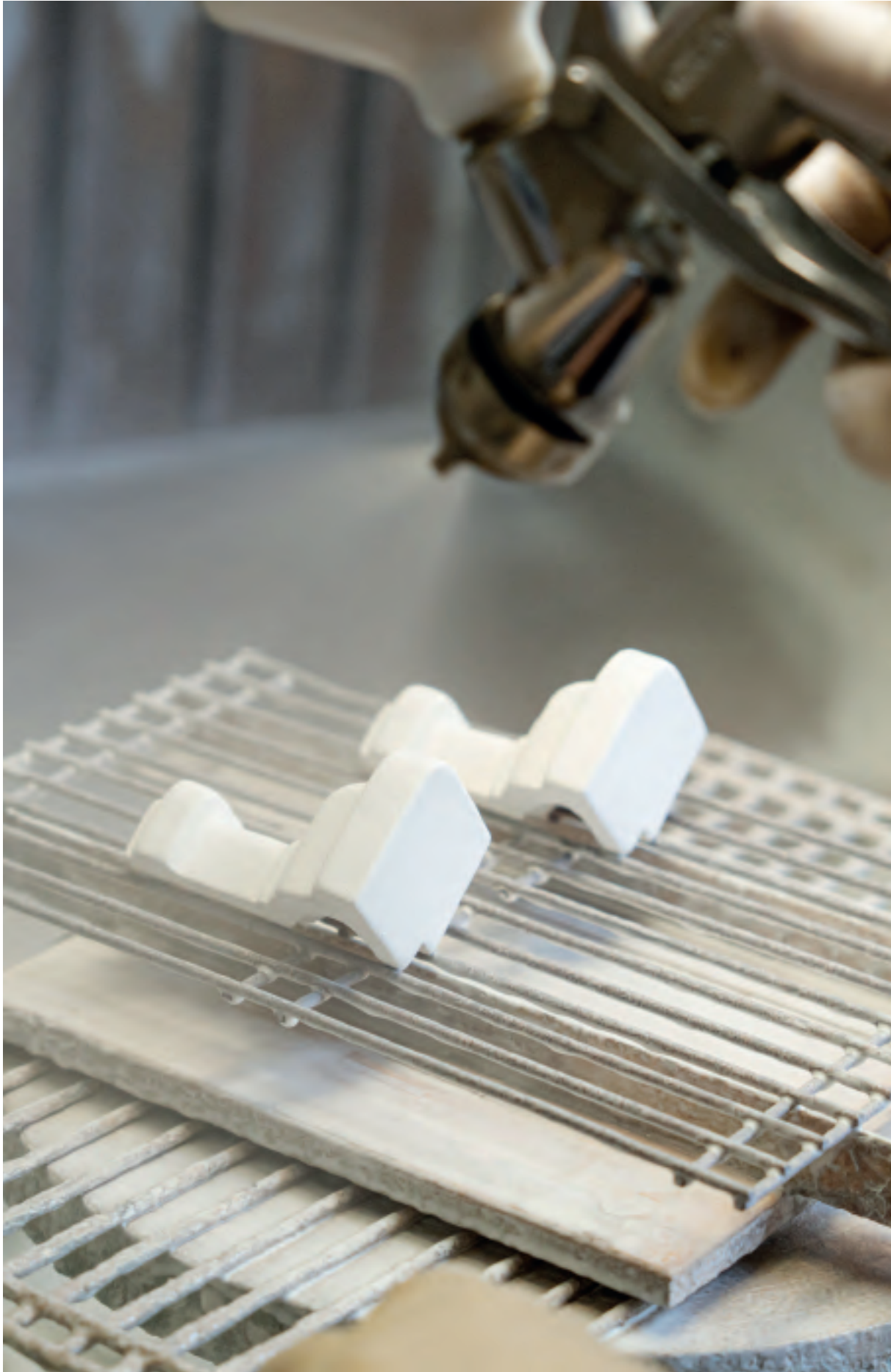

Fuoco e forma / *Fire and shape*

L'amore per il dettaglio e per le finiture di pregio ci ha condotto nel tempo ad andare contro corrente. Mentre il mondo cerca la produttività e la quantità, noi cerchiamo di dare valore a ogni singolo prodotto. Per questo produciamo ancora in bicottura, talvolta con lavorazioni puramente manuali: perché ogni pezzo conta.

The love for detail and fine finishes has led us over time to go against the others. While the world seeks for productivity and quantity, we try to give value to every single product. This is why we still manufacture in double firing, sometimes through purely manual processings: because every piece is important.









Index

Le Boiserie *The Boiserie*



Elegance 28



Elegance 2.0 54



Boiserie Origins 68

Gres Porcellanato *Porcelain Stoneware*



Brera 110



Pitti 128

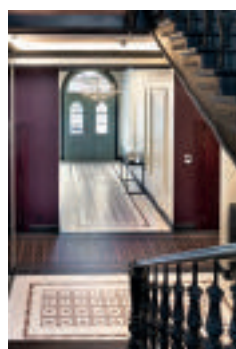

Old England 144

Rivestimenti *Coverings*

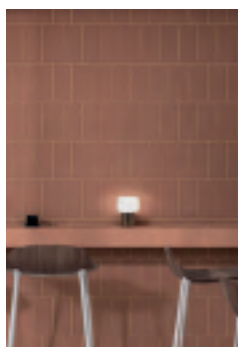

Nexus 184

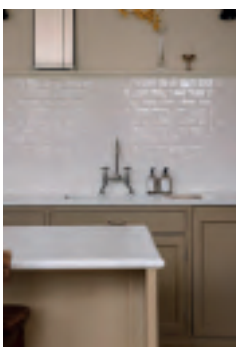

Essenze 196



Melange 226

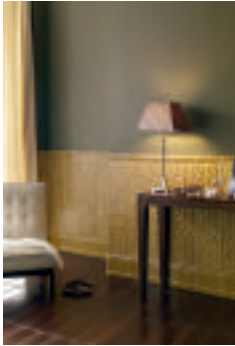

Epoque 90



Althaus 166



Vintage 236

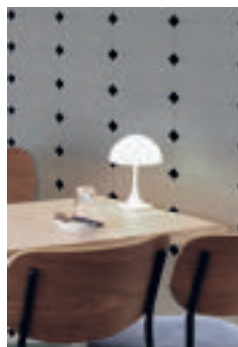

New Classic 248



Formelle 268



Shades of Art 290

**Un nuovo
legame cromatico**

*A new
chromatic bond*

Nella nostra lunga storia ceramica abbiamo fatto dell'eleganza e della ricerca del dettaglio i nostri tratti distintivi. Le collezioni Elegance e Boiserie hanno da sempre uno stile unico, che sfida il tempo; la serie Old England unisce da anni l'eleganza del piccolo formato e dell'Ottagono al decoro fatto con i retini e la pasta serigrafica. Tutto ciò unito alle caratteristiche tecniche R10. Abbiamo ora deciso di creare un trait d'union, un percorso cromatico che unisca le collezioni create durante la nostra storia e che ci rendono unici.

Da questo concetto nasce la ricerca fatta sugli impasti del gres porcellanato, su una nuova proposta di smalti sulla stessa tonalità cromatica di Boiserie, e sulla collezione Nexus, che con toni più tenui costruisce un percorso di colore con cui si può giocare sia nel monocolor che nel contrasto.

Questi tre mondi costruiscono un legame cromatico che lascia spazio a infinite possibilità creative.

Throughout our long history in ceramics, we have made elegance and attention to details our hallmarks.

The ELEGANCE and BOISERIE collections have always had a unique, timeless style; the OLD ENGLAND series has been combining small and octagonal formats' elegance with decorative screens, silk-screen paste and the technical characteristics of R10.

We have now decided to create a common thread, a chromatic link that unites the collections created throughout our history and that make us unique.

From this concept comes the research carried out on porcelain stonewares' bodies, on a new glaze proposal in the same color tone as BOISERIE, and on the brand new collection NEXUS, which, with finer tones, creates a color journey that can be played with both in unicolor and in contrast.

These three worlds create a chromatic bond that leaves room for infinite creative possibilities.

Colore e materia/ *Color and material*

Abbiamo definito una palette cromatica che crei un legame tra tutte le nostre tipologie di prodotto, creando armonie tra superfici diverse. L'obiettivo è permettere la più ampia creatività nella progettazione degli ambienti giocando con le superfici ma nella stessa tonalità colore, dalla boiserie al pavimento e al rivestimento. Il punto di partenza è sempre un riferimento colore univoco, una tonalità madre che guida ogni declinazione.

We selected a colour palette that creates a link between all our product types, creating harmonies between different surfaces. The goal is to allow the widest creativity in environments' designing by playing with surfaces in the same colour shade, from Boiserie to floor and wall tiles. The starting point is always a unique colour reference, a major tone that guides every declination.

Boiserie Origins *in The Boiserie*

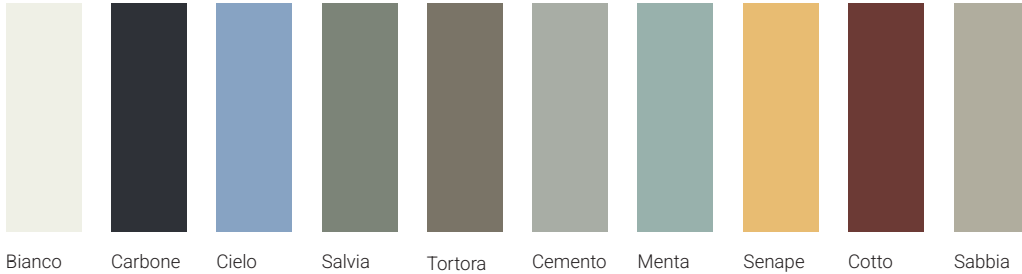

Gres Porcellanato / Porcelain Stoneware all collections

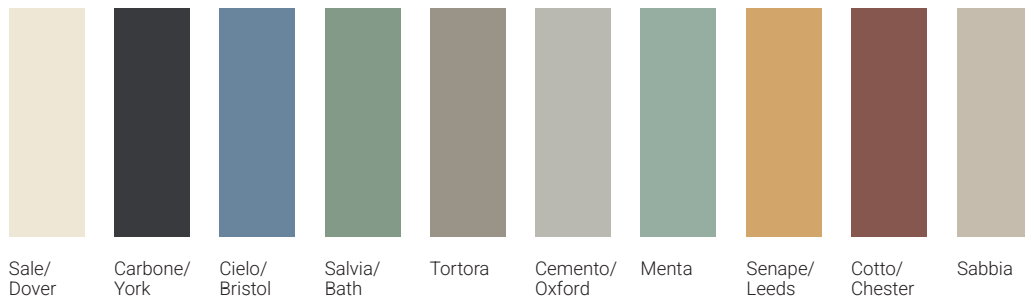

Nexus *in Coverings*

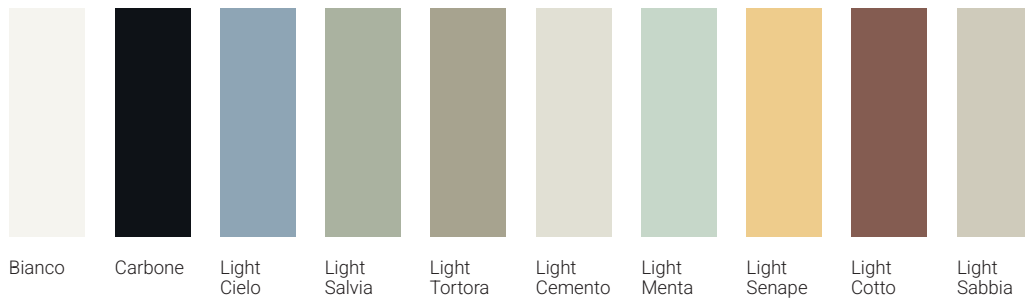

Riferimento NCS a solo scopo orientativo / NCS Reference for guidance only

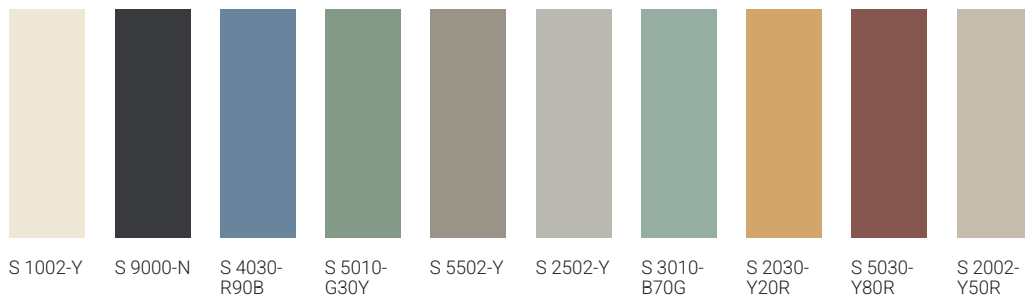

NB. I colori mostrati sono tra loro coordinabili ma non identici. Sebbene derivino da uno stesso riferimento cromatico NCS, utilizzato come base progettuale, ogni famiglia presenta variazioni specifiche all'interno della propria collezione. Di conseguenza, le tonalità riprodotte in questo catalogo hanno valore puramente indicativo. Per una valutazione accurata del colore, si consiglia di fare sempre riferimento ai campioni materici originali delle singole collezioni.

Note: The colors shown are coordinated but not identical. While they are based on a common NCS reference used in the design phase, each product family features specific variations within its own collection. Therefore, the colors presented in this catalog are to be considered purely indicative. For an accurate color match, it is always recommended to refer to the original material samples of each collection.

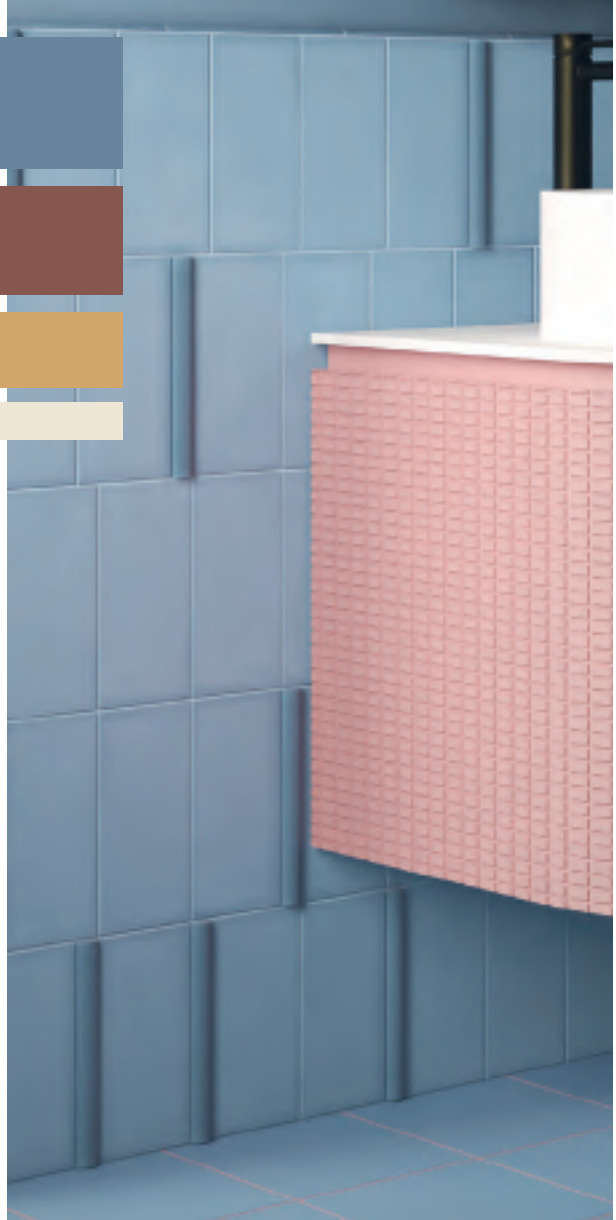

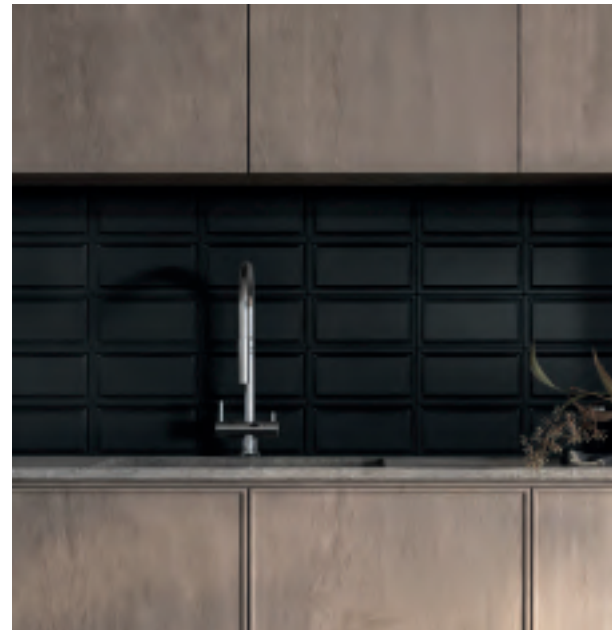

Le Boiserie

The Boiserie

Eleganza ceramica ispirata alla tradizione del legno, reinterpretata in chiave contemporanea. Perfetta per ambienti country, vintage, shabby-chic, tradizionali, cottage o altre declinazioni stilistiche, la serie Le Boiserie valorizza ogni dettaglio, conferendo personalità agli spazi. La versatilità è uno dei punti di forza: grazie alle caratteristiche estetiche e materiche, arricchisce ogni ambiente con stile e raffinatezza. Realizzata tramite bicottura in pasta bianca, garantisce qualità superiore e finitura impeccabile, disponibile in versione opaca o lucida craquelé, per un effetto unico e sofisticato.

Ceramic elegance inspired by the tradition of wood, reinterpreted in a contemporary key. Perfect for country, vintage, shabby-chic, traditional, cottage or other stylistic settings, LE BOISERIE series enhances every detail, lending personality to each space. Versatility is one of its strengths: thanks to its aesthetic and inner characteristics, it enriches any space with style and refinement. Double-fired white body tile, it guarantees superior quality and an impeccable finish, available in both matt and craquele' versions, for a unique and sophisticated effect.

Elegance

Il grande formato di Elegance dona carattere ed eleganza agli ambienti. Disponibile in un'ampia gamma di varianti colore questa serie è una bicottura a pasta bianca da rivestimento, la superficie può essere in finitura matt oppure craquelé. Design tipicamente classico e lineare che richiama alle più tradizionali boiserie, ma con un decoro di foglie nel fondo che ne accentua l'effetto tridimensionale, grazie ai giochi di luce dati dal chiaroscuro del rilievo. Adatto a ristrutturazioni di ambienti classici e di valore artistico, come i restauri conservativi, ma anche a interni dal design contemporaneo.

The large size of Elegance gives character and elegance to the rooms. Available in a wide range of colors this collection is a double fired white body wall tile, the surface can be either matt or craquelé finished. Typically classic and linear design that recalls the more traditional boiserie, with a leaves' decoration that accentuates the three-dimensional effect, thanks to the play of light given by the relief's light and dark contrast. Suitable for renovating classic environments of artistic value, such as conservative restorations, but also for interiors with a contemporary design.



Snow Matt

Rivestimenti/Wall:
8,5x35 Elegance Finale Snow Matt - 20x35 Elegance Fascia Classica Snow Matt - 35x102 Elegance Classica Snow Matt -
15x35 Zoccolo Snow Matt

Pavimento/Floor:
30x30 Pitti Ottagono Salvia - 12,20x12,20 Pitti Tozzetto Salvia





Flint Matt

Rivestimenti/Wall:

- 15x35 Elegance Zoccolo Flint Matt
- 1,2x15 Elegance Ang. Zocc. Flint Matt
- 35x102 Elegance Classica Flint Matt
- 3,5x35 Elegance Bordura Flint Matt
- 1.2x25,3 Elegance Coprispigo Flint Matt

Pavimento/Floor:

- 20x20 Althaus Lipsia London/York

Cinder Matt - Flint Matt

Rivestimenti/Wall:
3.5x35 Elegance Bordura Cinder Matt
35x102 Elegance Decoro Cinder Matt
3.5x35 Elegance Bordura Flint Matt
35x102 Elegance Classica Flint Matt
35x102 Elegance Liscia Flint Matt
15x35 Elegance Zoccolo Flint Matt



Designed by Marika Baczmanska interior designer





Flint Matt

Rivestimenti/Wall:

35x102 Elegance Classica Flint Matt - 3,5x35 Elegance Bordura Flint Matt - 35x102 Elegance Liscia Flint Matt



Pine Matt

Rivestimenti/Wall:

15x35 Elegance Zoccolo Pine Matt - 1,2x15 Elegance Ang. Zocc. Pine Matt - 35x102 Elegance Classica Pine Matt - 8,5x35 Elegance Finale Pine Matt - 2,2x8,5 Elegance Ang.fin. Pine Matt - 1,2x25,3 Elegance Coprispigolo Pine Matt

Pavimento/Floor:

Brera 30x30 ottagonone carbone - 4x4 tozzetto sale

Cinder Craquelé

Rivestimenti/Wall:

- 15x35 Elegance Zoccolo Cinder Craquelé
- 35x102 Elegance Classica Cinder Craquelé
- 8,5x35 Elegance Finale Cinder Craquelé
- 35x102 Elegance Decoro Cinder Craquelé
- 3.5x35 Elegance Bordura Cinder Craquelé







Designed by E.Mortensen Nachf. GMBH

Snow Matt

Rivestimenti/Wall:
8,5x35 Elegance Finale Snow Matt - 35x102 Elegance Classica Snow Matt



Designed by architetto Luca Caprioli

Flint Matt

Rivestimenti/Wall:

3.5x35 Elegance Bordura Flint Matt - 1.5x3.5 Elegance Angolo Bordura Flint Matt - 35x102 Elegance Classica Flint Matt - 35x102 Elegance Liscia Flint Matt - 1.2x25.3 Elegance Coprispigolo Flint Matt

Pavimento/Floor:

20x20 Old England Ottagono York - 4x4 Old England Tozzetto Dover



Storm Matt

Rivestimenti/Wall:

8.5x35 Elegance Finale Storm Matt - 2.2x8.5 Elegance Angolo Finale Storm Matt - 35x102 Elegance Decoro Storm Matt - 1.2x25.3 Elegance Coprispigo Storm Matt - 15x35 Elegance Zoccolo Storm Matt - 1.2x15 Elegance Angolo Zoccolo Storm Matt

Special Pieces



Finale
8,5x35 cm

1



Angolo finale
2,2x8,5 cm

2



Coprispigolo
1,2x25,3

3

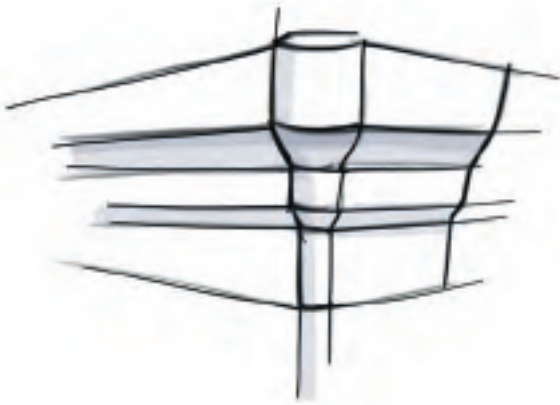

Elegance Matt

Formato 35x102 / Size 35x102 13,78 x 40,15"

Spessore: ca. 10 mm / Thickness: ca. 0,4
69 Price List (pz) Classica - 4 Price List (pz) Liscia

Classica + Liscia

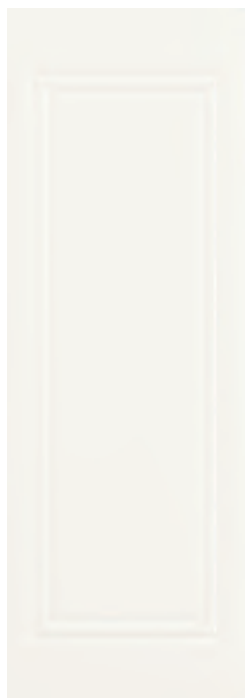

Classica
Snow Matt
ELGCLM01



Classica
Bone Matt
ELGCLM02



Classica
Cinder Matt
ELGCLM03



Classica
Pine Matt
ELGCLM05



Classica
Storm Matt
ELGCLM06



Classica
Flint Matt
ELGCLM07

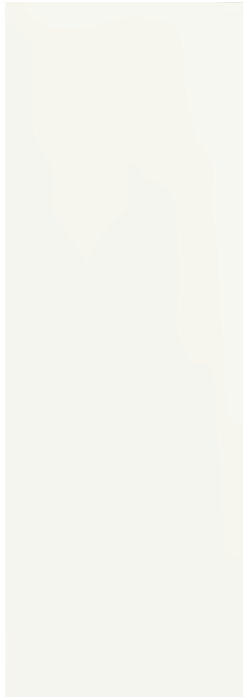

Liscia
Snow Matt
ELGLIM01



Liscia
Bone Matt
ELGLIM02



Liscia
Cinder Matt
ELGLIM03



Liscia
Pine Matt
ELGLIM05



Liscia
Storm Matt
ELGLIM06



Liscia
Flint Matt
ELGLIM07

Elegance Matt

Formato 35x102 / Size 35x102 13,78 x 40,15"

Spessore: ca. 10 mm / Thickness: ca. 0,4
69 Price List (pz) Decoro

Decoro

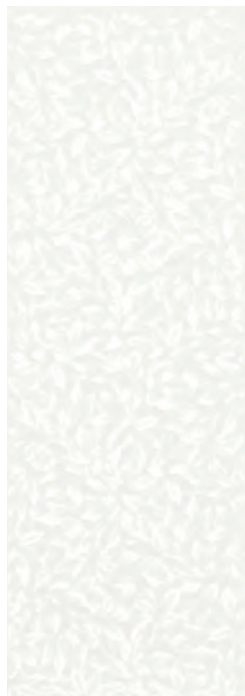

Decoro
Snow Matt
ELGDEM01

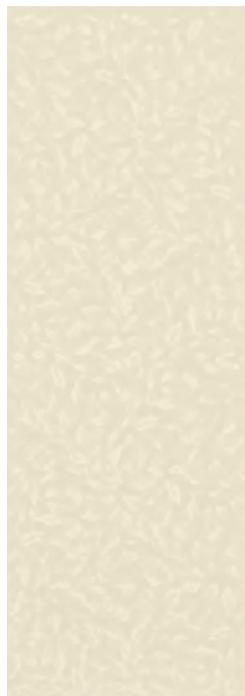

Decoro
Bone Matt
ELGDEM02



Decoro
Cinder Matt
ELGDEM03



Decoro
Pine Matt
ELGDEM05

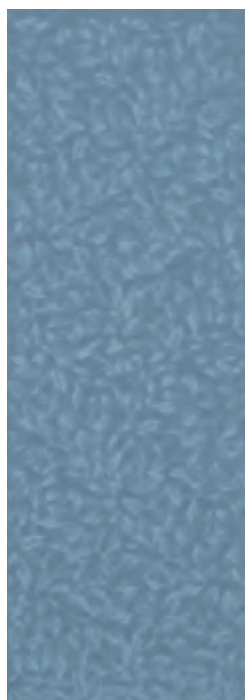

Decoro
Storm Matt
ELGDEM06

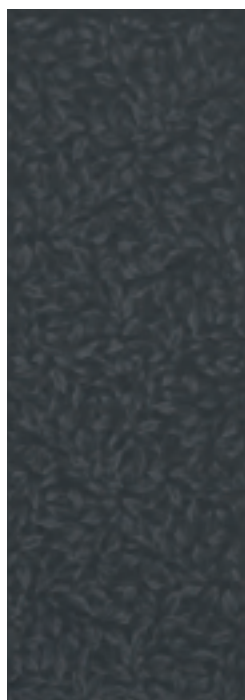







Decoro
Flint Matt
ELGDEM07

Pezzi speciali / Special pieces

Finale*

8,5X35 cm - 3,35 x 13,78 "
28 Price List (pz)









-  Snow Matt
FINELM01
-  Bone Matt
FINELM02
-  Cinder Matt
FINELM03
-  Pine Matt
FINELM05
-  Storm Matt
FINELM06
-  Flint Matt
FINELM07

Ang. Finale*

2,2x8,5 cm - 0,87x 3,35 "
59 Price List (pz)







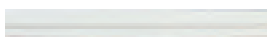

-  Snow Matt
FIAELM01
-  Bone Matt
FIAELM02
-  Cinder Matt
FIAELM03
-  Pine Matt
FIAELM05
-  Storm Matt
FIAELM06
-  Flint Matt
FIAELM07

Bordura*

3,5x35 cm - 1,38x13,78 "
74 Price List (pz)









-  Snow Matt
BOELM01
-  Bone Matt
BOELM02
-  Cinder Matt
BOELM03
-  Pine Matt
BOELM05
-  Storm Matt
BOELM06
-  Flint Matt
BOELM07

Angolo Bordura*

1,5x3,5 cm - 0,59x1,38 "
124 Price List (pz)









-  Snow Matt
BOAELM01
-  Bone Matt
BOAELM02
-  Cinder Matt
BOAELM03
-  Pine Matt
BOAELM05
-  Storm Matt
BOAELM06
-  Flint Matt
BOAELM07

Matita Classica

2,5X35 cm - 0,98x13,78 "
57 Price List (pz)







-  Snow Matt
MATELM01
-  Bone Matt
MATELM02
-  Cinder Matt
MATELM03
-  Pine Matt
MATELM05
-  Storm Matt
MATELM06
-  Flint Matt
MATELM07

Zoccolo

15X35 cm - 5,9x13,78 "
29 Price List (pz)









-  Snow Matt
ZOELM01
-  Bone Matt
ZOELM02
-  Cinder Matt
ZOELM03
-  Pine Matt
ZOELM05
-  Storm Matt
ZOELM06
-  Flint Matt
ZOELM07

Ang. Zoccolo

1,2x15 cm - 0,47x5,9 "
46 Price List (pz)









-  Snow Matt
ZOAELM01
-  Bone Matt
ZOAELM02
-  Cinder Matt
ZOAELM03
-  Pine Matt
ZOAELM05
-  Storm Matt
ZOAELM06
-  Flint Matt
ZOAELM07

Coprispigolo

1,2X25,3 cm - 0,47x9,96 "
56 Price List (pz)



-  Snow Matt
COPELM01
-  Bone Matt
COPELM02
-  Cinder Matt
COPELM03
-  Pine Matt
COPELM05
-  Storm Matt
COPELM06
-  Flint Matt
COPELM07

* Pezzi smaltati su lato superiore / Pieces glazed on top

Elegance Matt

Pezzi speciali decorativi/ *Decorative special pieces*

Spessore: ca. 10 mm/ Thickness: ca. 10,4

Fascia Classica

20x35 cm - 7,87x13,78"

29 Price List (pz)



Snow Matt
FACLM01



Bone Matt
FACLM02



Cinder Matt
FACLM03



Pine Matt
FACLM05



Storm Matt
FACLM06



Flint Matt
FACLM07

Fascia Decoro

20x35 cm - 7,87x13,78"

29 Price List (pz)

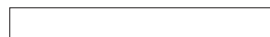

Snow Matt
FADEM01



Bone Matt
FADEM02



Cinder Matt
FADEM03



Pine Matt
FADEM05

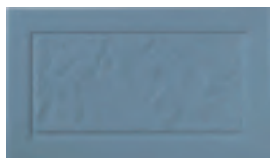

Storm Matt
FADEM06

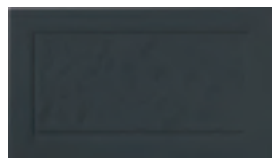

Flint Matt
FADEM07



Snow Matt

Rivestimenti/Wall:

8,5x35 Elegance Finale Snow Matt - 20x35 Elegance Fascia Classica Snow Matt - 35x102 Elegance Classica Snow Matt

Elegance Craquelé

Formato 35x102 / Size 35x102 13,78 x 40,15 "

Spessore: ca. 10 mm / Thickness: ca. 0,4
69 Price List (pz) Classica e Decoro - 4 Price List (pz) Liscia

Classica + Liscia + Decoro



Classica

Snow Craquelé
ELGCLQ1



Classica

Bone Craquelé
ELGCLQ2



Classica

Cinder Craquelé
ELGCLQ3

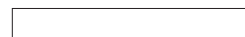

Liscia

Snow Craquelé
ELGLIQ1



Liscia

Bone Craquelé
ELGLIQ2



Liscia

Cinder Craquelé
ELGLIQ3



Decoro

Snow Craquelé
ELGDEQ1

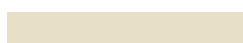

Decoro

Bone Craquelé
ELGDEQ2



Decoro

Cinder Craquelé
ELGDEQ3

Si consiglia di trattare gli smalti craquelé con impregnante prima della stuccatura
We suggest to treat the crackle glazes with appropriate sealer before grouting.



Elegance Craquelé

Pezzi speciali / Special pieces

Finale*

8,5X35 cm - 3,35 x 13,78 "
28 Price List (pz)





	Snow Craquelé FINELQ1
	Bone Craquelé FINELQ2
	Cinder Craquelé FINELQ3

Ang. Finale*

2,2x8,5 cm - 0,87x 3,35 "
59 Price List (pz)





	Snow Craquelé FIAELQ1
	Bone Craquelé FIAELQ2
	Cinder Craquelé FIAELQ3

Bordura*

3,5x35 cm - 1,38 x 13,78 "
74 Price List (pz)





	Snow Craquelé BORELQ1
	Bone Craquelé BORELQ2
	Cinder Craquelé BORELQ3

Angolo Bordura*

1,5x3,5 cm - 0,59x1,38 "
124 Price List (pz)





	Snow Craquelé BOAELQ1
	Bone Craquelé BOAELQ2
	Cinder Craquelé BOAELQ3

Matita Classica

2,5X35 cm - 0,98x13,78 "
57 Price List (pz)





	Snow Craquelé MATELQ1
	Bone Craquelé MATELQ2
	Cinder Craquelé MATELQ3

Zoccolo

15X35 cm - 5,9x13,78 "
29 Price List (pz)





	Snow Craquelé ZOELQ1
	Bone Craquelé ZOELQ2
	Cinder Craquelé ZOELQ3

Ang. Zoccolo

1,2x15 cm - 0,47x5,9 "
46 Price List (pz)





	Snow Craquelé ZOAELQ1
	Bone Craquelé ZOAELQ2
	Cinder Craquelé ZOAELQ3

Coprispigolo

1,2X25,3 cm - 0,47x9,96 "
56 Price List (pz)



	Snow Craquelé COPELQ1
	Bone Craquelé COPELQ2
	Cinder Craquelé COPELQ3

* Pezzi smaltati su lato superiore / Pieces glazed on top

Pezzi speciali decorativi/ *Decorative special pieces*

Spessore: ca. 10 mm/ *Thickness: ca. 10,4*

Fascia Classica

20x35 cm - 7,87x13,78"

29 Price List (pz)



Snow Craquelé
FACLQ1



Bone Craquelé
FACLQ2



Cinder Craquelé
FACLQ3

Fascia Decoro

20x35 cm - 7,87x13,78"

29 Price List (pz)

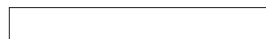

Snow Craquelé
FADEQ1



Bone Craquelé
FADEQ2



Cinder Craquelé
FADEQ3

Si consiglia di trattare gli smalti craquelé con impregnante prima della stuccatura
We suggest to treat the crackle glazes with appropriate sealer before grouting.

Elegance



Cinder Craquelé

Rivestimenti/Wall:

35x102 Elegance Classica Cinder Craquelé - 8,5x35 Elegance Finale Cinder Craquelé - 15x35 Elegance Zoccolo Cinder Craquelé
35x102 Elegance Decoro Cinder Craquelé - 3.5x35 Elegance Bordura Cinder Craquelé

Lista imballaggi per box / Packing list per box

Descrizione / Description	kg box	pz. box	mq box	box pallet	kg. pallet
35x102 Formato 35x102 Classica	5,8	2	0,714	26	150,80
35x102 Formato 35x102 Decoro	6,4	2	0,714	26	166,40
35x102 Formato 35x102 Liscia	6	2	0,714	26	156
8,5x35 Finale	6,6	12	-	-	-
2,5x8,5 Angolo Finale	1,1	40	-	-	-
3,5x35 Bordura	5,4	24	-	-	-
1,5x3,5 Angolo Bordura	0,5	60	-	-	-
2,5x35 Matita Classica	6,8	36	-	-	-
15x35 Zoccolo	18,20	12	-	-	-
1,2x15 Angolo Zoccolo	0,7	30	-	-	-
1,2x25,3 Coprispigolo	1	22	-	-	-
20x35 Fascia Classica	1,083	12	0,07	-	-
20x35 Fascia Decoro	1,083	12	0,07	-	-

Elegance 2.0

I nuovi colori di Elegance 2.0 sono estremamente versatili. Possono essere utilizzati per creare ambienti monocromatici o abbinati tra loro per un effetto dinamico e moderno, integrandosi perfettamente sia alla linea Elegance che a superfici in legno. Disponibile in un'ampia gamma di tinte pastello, questa serie è una bicottura a pasta bianca con finitura matt. Il design classico e lineare richiama le tradizionali boiserie. Adatto a ristrutturazioni di ambienti classici e artistici, così come a interni dal design contemporaneo.

The new Elegance 2.0 colours are extremely versatile. They can be used to create both monochromatic or combined environments for a dynamic and modern effect, integrating themselves perfectly to both the Elegance series and wooden surfaces. Available in a wide range of pastel colours, this series is a white-body double-fired tile with matt finishing. The classic and linear design recalls the traditional boiserie. It is suitable for renovations of classic and artistic environments, as well as contemporary designed interiors.



Snow Matt - Light Pink Matt

Rivestimenti/Wall:

8,5x35 Elegance 2.0 Finale Snow Matt - 15x35 Elegance 2.0 Zoccolo Snow Matt - 35x102 Elegance 2.0 Liscia Snow Matt - 8,5x35 Elegance 2.0 Finale Light Pink - 15x35 Elegance 2.0 Zoccolo Light Pink 35x102 Elegance 2.0 Classica Light Pink

Pavimento/Floor:

30x30 Pitti Ottagono Sale - 12,2x12,2 Pitti Tozzetto Sale





Light Blue Matt

Rivestimenti/Wall:

8,5x35 Elegance 2.0 Finale Light Blue

35x102 Elegance 2.0 Classica Light Blue

15x35 Elegance 2.0 Zoccolo Light Blue



Yellow Matt

Rivestimenti/Wall:
8,5x35 Elegance 2.0 Finale Yellow -35x102 Elegance 2.0 Classica Yellow - 15x35 Elegance 2.0 Zoccolo Yellow

Pavimento/Floor:
20x20 Althaus Lipsia Leeds/Chester



Pastel Turquoise Matt

Rivestimenti/Wall:

8,5x35 Elegance 2.0 Finale Pastel Turquoise - 20x35 Elegance 2.0 Fascia Classica Pastel Turquoise - 35x102 Elegance 2.0 Liscia Pastel Turquoise - 15x35 Elegance 2.0 Zoccolo Pastel Turquoise



Pastel Green Matt

Rivestimenti/Wall:

15x35 Elegance 2.0 Zoccolo Pastel Green - 35x102 Elegance 2.0 Liscia Pastel Green - 3,5x35 Elegance 2.0 Bordura Pastel Green - 35x102 Elegance 2.0 Classica Pastel Green

Pavimento/Floor:

30x30 Pitti Ottagono Sale - 12,2x12,2 Pitti Tozzetto B Sale + Menta

Special Pieces



Zoccolo
15x35

1



Bordura
3.5x35

2



Elegance 2.0 Matt

Formato 35x102 / Size 35x102 13,78 x 40,15"

Spessore: ca. 10 mm / Thickness: ca. 0,4
69 Price List (pz) Classica - 4 Price List (pz) Liscia

Classica + Liscia

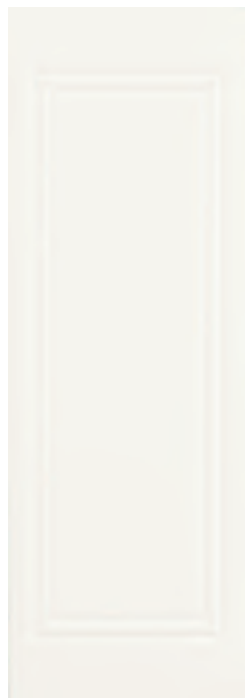

Classica
Snow Matt
ELGCLM01



Classica
Pastel Green
ELGCLP50



Classica
Light Blue
ELGCLP51



Classica
Pastel Turquoise
ELGCLP52



Classica
Light Pink
ELGCLP53



Classica
Yellow
ELGCLP54

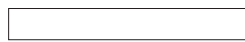
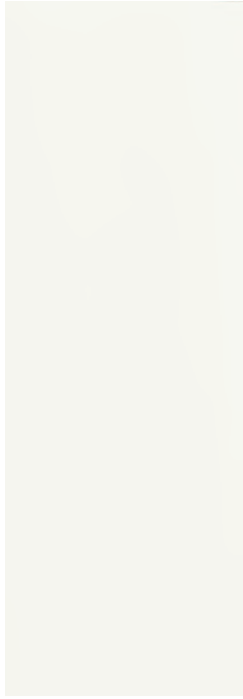

Liscia
Snow Matt
ELGLIM01



Liscia
Pastel Green
ELGLIP50



Liscia
Light Blue
ELGLIP51



Liscia
Pastel Turquoise
ELGLIP52



Liscia
Light Pink
ELGLIP53



Liscia
Yellow
ELGLIP54







Elegance 2.0 Matt

Pezzi speciali / Special pieces

Finale*

8,5x35 cm - 3,35 x 13,78"
28 Price List (pz)









	Snow Matt FINELM01
	Pastel Green FINELP50
	Light Blue FINELP51
	Pastel Turquoise FINELP52
	Light Pink FINELP53
	Yellow FINELP54

Ang. Finale*

2,2x8,5 cm - 0,87x 3,35"
59 Price List (pz)









	Snow Matt FIAELM01
	Pastel Green FIAELP50
	Light Blue FIAELP51
	Pastel Turquoise FIAELP52
	Light Pink FIAELP53
	Yellow FIAELP54

Bordura*

3,5x35 cm - 1,38 x 13,78"
74 Price List (pz)









	Snow Matt BORELM01
	Pastel Green BORELP50
	Light Blue BORELP51
	Pastel Turquoise BORELP52
	Light Pink BORELP53
	Yellow BORELP54

Angolo Bordura*

1,5x3,5 cm - 0,59x1,38"
124 Price List (pz)









	Snow Matt BOAELM01
	Pastel Green BOAELP50
	Light Blue BOAELP51
	Pastel Turquoise BOAELP52
	Light Pink BOAELP53
	Yellow BOAELP54

Zoccolo

15x35 cm - 5,9x13,78"
29 Price List (pz)









	Snow Matt ZOELM01
	Pastel Green ZOELP50
	Light Blue ZOELP51
	Pastel Turquoise ZOELP52
	Light Pink ZOELP53
	Yellow ZOELP54

Ang. Zoccolo

1,2x15 cm - 0,47x5,9"
46 Price List (pz)









	Snow Matt ZOAELM01
	Pastel Green ZOAELP50
	Light Blue ZOAELP51
	Pastel Turquoise ZOAELP52
	Light Pink ZOAELP53
	Yellow ZOAELP54

Coprispigolo

1,2x25,3 cm - 0,47x9,96"
56 Price List (pz)



	Snow Matt COPELM01
	Pastel Green COPELP50
	Light Blue COPELP51
	Pastel Turquoise COPELP52
	Light Pink COPELP53
	Yellow COPELP54

* Pezzi smaltati su lato superiore / Pieces glazed on top

Pezzi speciali decorativi/ *Decorative special pieces*

Spessore: ca. 10 mm/ Thickness: ca. 10,4

Fascia Classica

20x35 cm - 7,87x13,78"
29 Price List (pz)



Snow Matt
FACLM01



Pastel Green
FACLP50



Light Blue
FACLP51



Pastel Turquoise
FACLP52



Light Pink
FACLP53



Yellow
FACLP54

Fascia Decoro

20x35 cm - 7,87x13,78"
29 Price List (pz)

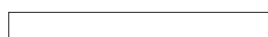
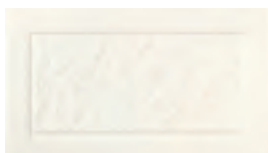

Snow Matt
FADEM01



Pastel Green
FADEP50



Light Blue
FADEP51



Pastel Turquoise
FADEP52



Light Pink
FADEP53



Yellow
FADEP54

Elegance 2.0



Light Blue Matt

Rivestimenti/Wall:

8,5x35 Elegance 2.0 Finale Light Blue - 35x102 Elegance 2.0 Classica Light Blue - 15x35 Elegance 2.0 Zoccolo Light Blue

Lista imballaggi per box / Packing list per box

Descrizione / Description	kg box	pz. box	mq box	box pallet	kg. pallet
35x102 Formato 35x102 Classica	5,8	2	0,714	26	150,80
35x102 Formato 35x102 Liscia	6	2	0,714	26	156
8,5x35 Finale	6,6	12	-	-	-
2,5x8,5 Angolo Finale	1,1	40	-	-	-
3,5x35 Bordura	5,4	24	-	-	-
1,5x3,5 Angolo Bordura	0,5	60	-	-	-
15x35 Zoccolo	18,20	12	-	-	-
1.2x15 Angolo Zoccolo	0,7	30	-	-	-
1,2x25,3 Coprispigolo	1	22	-	-	-
20x35 Fascia Classica	1,083	12	0,07	-	-
20x35 Fascia Decoro	1,083	12	0,07	-	-

Boiserie Origins

Boiserie Origins, ispirata alla tradizionale boiserie in legno, è la prima e storica serie creata da Grazia in questo stile. Bicottura pasta bianca da rivestimento con finitura sia matt che lucida craquelé. La caratteristica di questa serie è la versatilità che, a seconda dell'arredamento scelto può sottolineare il gusto country, vintage, shabby-chic, tradizionale o cottage. Rivisitata e arricchita di numerosi colori di tendenza, si presta da oggi anche ad ambienti contemporanei.

Boiserie Origins, inspired by traditional wood paneling, is the first and historic series created by Grazia in this style. Double-fired white body wall tiles with both a matt and a craquelé finish. The characteristic feature of this collection is its versatility, which, depending on the chosen furniture, can highlight country, vintage, shabby-chic, traditional or cottage styles. Revisited and enriched with numerous trendy colours, it is now suitable also for contemporary environments.



Salvia Matt - Light Salvia Matt

Rivestimenti/Wall:
20x20 Boiserie Origins Zoccolo Salvia Matt - 20x80 Boiserie Origins Salvia Matt - 10x20 Nexus Light Salvia Matt

Pavimento/Floor:
30x30 Brera Ottagono Salvia - 4x4 Brera Tozzetto Carbone

Bianco matt

Rivestimenti/Wall:

- 12x20 Boiserie Origins Finale Bianco Matt
- 12x3 Boiserie Origins Angolo Finale Bianco Matt
- 20x80 Boiserie Origins Boiserie Bianco Matt
- 20x20 Boiserie Origins Zoccolo Bianco Matt
- 2x20 Boiserie Origins Angolo Zoccolo Bianco Matt
- 1,2x20 Boiserie Origins Cosprispigolo Bianco Matt

Pavimento/Floor:

- 30x30 Pitti Ottagono Sale
- 12,20x12,20 Pitti Tozzetto Cotto







Bianco Matt

Rivestimenti/Wall:

20x80 Boiserie Origins Boiserie Bianco Matt - 8x20 Boiserie Origins Gemme Pino Glossy - 6.5x20 Boiserie Origins Toro Bianco Matt - 6.5x3 Boiserie Origins Angolo Est. Par.toro Bianco Matt - 1,2x20 Boiserie Origins Coprispigolo Bianco Matt



Designed by Muse Ceramiche

Bianco Matt

Rivestimenti/Wall:
20x80 Boiserie Origins Electa Bianco Matt - 5.5x20 Boiserie Origins Toro Electa Bianco Matt





Sabbia matt - Carbone matt

Rivestimenti/Wall:
20x20 Boiserie Origins Zoccolo Carbone Matt
20x80 Boiserie Origins Boiserie Sabbia Matt

Pavimento/Floor:
15x30 Brera Tortora
7,3x30 Brera Listello Sabbia
7,3x30 Brera Listello Carbone



Beige Craquelé

Rivestimenti/Wall:

20x80 Boiserie Origins Boiserie Beige Craquelé - 12x20 Boiserie Origins Finale Beige Craquelé - 12x3 Boiserie Origins Angolo Finale Beige Craquelé - 1,2x20 Boiserie Origins Coprispigo Beige Craquelé



Beige Matt

Rivestimenti/Wall:
20x80 Boiserie Origins Electa Beige Matt - 10x20 Boiserie Origins Finale Electa Beige Matt

Beige Craquelé

Rivestimenti/Wall:

- 20x80 Boiserie Origins Boiserie Beige Craquelé
- 6,5x20 Boiserie Origins Toro Beige Craquelé
- 6,5x3 Boiserie Origins Ang. Est.toro Beige Craquelé
- 6,5x20 Boiserie Origins Square Genziana Glossy
- 20x20 Boiserie Origins Zoccolo Beige Craquelé
- 1,2x20 Boiserie Origins Coprispigolo Beige Craquelé
- 6,5x13 Essenze Genziana
- 13x13 Essenze Primula







Beige Craquelé

Rivestimenti/Wall:

20x80 Boiserie Origins Boiserie Beige Craquelé - 6,5x20 Boiserie Origins Toro Beige Craquelé - 6,5x3 Boiserie Origins Ang. Est. toro Beige Craquelé - 6,5x20 Boiserie Origins Square Genziana Glossy 1,2x20 Boiserie Origins Coprispigo Beige Craquelé

Special Pieces



Angolo esterno toro
6,5x3 cm



Toro
6,5x20 cm



Coprispigolo
1,2x20 cm



Square
6,5x20 cm

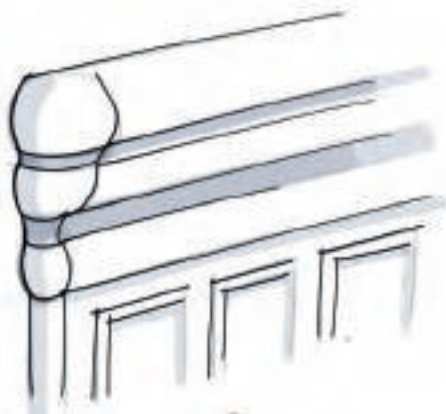

Boiserie Origins Matt

Formato 20x80 / Size 20x80 7,87x31,50

Spessore Boiserie: ca. 8/10 mm / Thickness Boiserie: ca. 0,3/0,4
Spessore Electa: ca. 11,5 mm / Thickness Electa: ca. 0,45
52 Price List (pz) Boiserie + Electa

Boiserie + Electa



Boiserie
Bianco Matt
BOI01

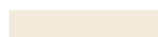

Boiserie
Beige Matt
BOI06

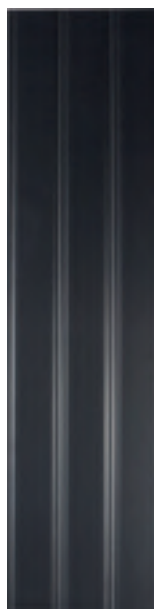

Boiserie
Carbone Matt
BOI11



Boiserie
Cielo Matt
BOI12



Boiserie
Salvia Matt
BOI13

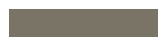

Boiserie
Tortora Matt
BOI14



Boiserie
Cemento Matt
BOI15



Boiserie
Menta Matt
BOI16



Boiserie
Senape Matt
BOI17



Boiserie
Cotto Matt
BOI18



Boiserie
Sabbia Matt
BOI19



Electa
Bianco Matt
CLB2



Electa
Beige Matt
CLB4

Boiserie Origins Matt

Pezzi speciali / Special pieces

Boiserie + Electa

Boiserie

Toro*

6,5x20 cm - 2,56x7,87
55 Price List (pz)



	Bianco Matt TO01
	Beige Matt TO06
	Carbone Matt TO111
	Cielo Matt TO112
	Salvia Matt TO113
	Tortora Matt TO114
	Cemento Matt TO115
	Menta Matt TO116
	Senape Matt TO117
	Cotto Matt TO118
	Sabbia Matt TO119

Ang. est. toro*

6,5x3 cm - 2,56x1,18
105 Price List (pz)



	Bianco Matt TOA01
	Beige Matt TOA06
	Carbone Matt TOA111
	Cielo Matt TOA112
	Salvia Matt TOA113
	Tortora Matt TOA114
	Cemento Matt TOA115
	Menta Matt TOA116
	Senape Matt TOA117
	Cotto Matt TOA118
	Sabbia Matt TOA119

Finale*

12x20 cm - 4,72x7,87
58 Price List (pz)



	Bianco Matt FIN01
	Beige Matt FIN06
	Carbone Matt FIN111
	Cielo Matt FIN112
	Salvia Matt FIN113
	Tortora Matt FIN114
	Cemento Matt FIN115
	Menta Matt FIN116
	Senape Matt FIN117
	Cotto Matt FIN118
	Sabbia Matt FIN119

Ang. finale*

12x3 cm - 4,72x1,18
72 Price List (pz)



	Bianco Matt FINA01
	Beige Matt FINA06
	Carbone Matt FINA111
	Cielo Matt FINA112
	Salvia Matt FINA113
	Tortora Matt FINA114
	Cemento Matt FINA115
	Menta Matt FINA116
	Senape Matt FINA117
	Cotto Matt FINA118
	Sabbia Matt FINA119

Zoccolo

20x20 cm - 7,87x7,87
22 Price List (pz)



	Bianco Matt ZO01
	Beige Matt ZO06
	Carbone Matt ZO111
	Cielo Matt ZO112
	Salvia Matt ZO113
	Tortora Matt ZO114
	Cemento Matt ZO115
	Menta Matt ZO116
	Senape Matt ZO117
	Cotto Matt ZO118
	Sabbia Matt ZO119

Ang. zoccolo

2,2x20 cm - 0,87x7,87
72 Price List (pz)



	Bianco Matt ZOA01
	Beige Matt ZOA06
	Carbone Matt ZOA111
	Cielo Matt ZOA112
	Salvia Matt ZOA113
	Tortora Matt ZOA114
	Cemento Matt ZOA115
	Menta Matt ZOA116
	Senape Matt ZOA117
	Cotto Matt ZOA118
	Sabbia Matt ZOA119

Coprispigolo

1,2x20 cm - 0,47x7,87
19 Price List (pz)



	Bianco Matt COP01
	Beige Matt COP06
	Carbone Matt COP111
	Cielo Matt COP112
	Salvia Matt COP113
	Tortora Matt COP114
	Cemento Matt COP115
	Menta Matt COP116
	Senape Matt COP117
	Cotto Matt COP118
	Sabbia Matt COP119

* Pezzi smaltati su lato superiore/
Pieces glazed on top

Electa

Toro*

5,6x20 cm - 2,20x7,87
55 Price List (pz)

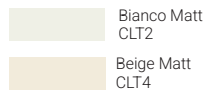

Ang. est. toro*

5,6x2,5 cm - 2,20x0,98
105 Price List (pz)

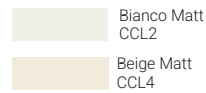

Finale*

10x20 cm - 3,94x7,87 "
58 Price List (pz)

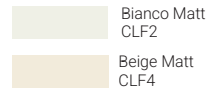

Ang. est. finale*

10x3 cm - 7,87x1,18 "
72 Price List (pz)

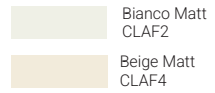

Zoccolo

20x20 cm - 7,87x7,87
22 Price List (pz)



Ang. est. zoccolo

20x2 cm - 7,87x0,79 "
72 Price List (pz)

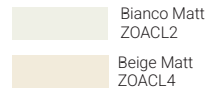

Pezzi speciali decorativi/ Decorative special pieces

Boiserie

Matt/Glossy

Gemme

8x20 cm - 3,15x7,87 "
104 Price List (pz)



Bianco Matt
GE01



Beige Matt
GE06



Genziana Glossy
GE11



Pino Glossy
GE12

Square

6,5x20 cm - 2,56x7,87 "
104 Price List (pz)



Bianco Matt
SQ01

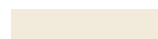

Beige Matt
SQ06



Genziana Glossy-
SQ11



Pino Glossy
SQ12

Boiserie Origins Craquelè

Formato 20x80 / Size 20x80 7,87x31,50

Spessore Boiserie: ca. 8/10 mm / Thickness Boiserie: ca. *0,3/0,4
 Spessore Electa: ca. 11,5 mm / Thickness Electa: ca. *0,45
52 Price List (pz) Boiserie + Electa

Boiserie + Electa



Boiserie

Beige Craquelè
BOI02



Boiserie

Bianco Craquelè
BOI05



Electa

Bianco Craquelè
CLB1



Electa

Beige Craquelè
CLB3

Pezzi speciali / Special pieces

Boiserie + Electa

Boiserie

Toro*

6,5x20 cm - 2,56x7,87"
55 Price List (pz)



Beige Craquelè
TO02
Bianco Craquelè
TO05

Ang. est. toro*

6,5x3 cm - 2,56x1,18"
105 Price List (pz)



Beige Craquelè
TOA02
Bianco Craquelè
TOA05

Finale*

12x20 cm - 4,72x7,87"
58 Price List (pz)



Beige Craquelè
FIN02
Bianco Craquelè
FIN05

Ang. finale*

12x3 cm - 4,72x1,18"
72 Price List (pz)



Beige Craquelè
FINA02
Bianco Craquelè
FINA05

Zoccolo

20x20 cm - 7,87x7,87"
22 Price List (pz)



Beige Craquelè
Z002
Bianco Craquelè
Z005

Ang. zoccolo

2,2x20 cm - 0,87x7,87"
72 Price List (pz)



Beige Craquelè
ZOA02
Bianco Craquelè
ZOA05

Coprispigolo

1,2x20 cm - 0,47x7,87"
19 Price List (pz)



Beige Craquelè
COP02
Bianco Craquelè
COP05

Electa

Toro*

5,6X20 cm - 2,20x7,87" *
55 Price List (pz)



Beige Craquelè
CLT3
Bianco Craquelè
CLT1

Ang. est. toro*

5,6X2,5 cm - 2,20x0,98"
105 Price List (pz)



Beige Craquelè
CCL3
Bianco Craquelè
CCL1

Finale*

10X20 cm - 3,94x7,87"
58 Price List (pz)



Beige Craquelè
CLF3
Bianco Craquelè
CLF1

Ang. est. finale*

10X3 cm - 7,87x1,18"
72 Price List (pz)



Beige Craquelè
CLAF3
Bianco Craquelè
CLAF1

Zoccolo

20X20 cm - 7,87x7,87" *
22 Price List (pz)

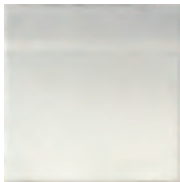

Beige Craquelè
ZOCL3
Bianco Craquelè
ZOCL1

Ang. est. zoccolo

20X2 cm - 7,87x0,79"
72 Price List (pz)



Beige Craquelè
ZOACL3
Bianco Craquelè
ZOACL1

Pezzi speciali decorativi/ *Decorative special pieces*

Boiserie

Gemme

8x20 cm - 3,15x7,87"
104 Price List (pz)



Beige Craquelè
GE02



Bianco Craquelè
GE05

Square

6,5x20 cm - 2,56x7,87"
104 Price List (pz)



Beige Craquelè
SQ02



Bianco Craquelè
SQ05

* Pezzi smaltati su lato superiore / Pieces glazed on top

Si consiglia di trattare gli smalti craquelé con impregnante prima della stuccatura.
We suggest to treat the crackle glazes with appropriate sealer before grouting.

Boiserie Origins



Sabbia matt - Carbone matt

Rivestimenti/Wall:

20x20 Boiserie Origins Zoccolo Carbone Matt - 20x80 Boiserie Origins Boiserie Sabbia Matt

Lista imballaggi per box / Packing list per box

Descrizione / Description		kg box	pz. box	mq box	box pallet	kg pallet
Boiserie						
20x80	boiserie	12,650	5	0,80	42	531,30
6,5x20	toro	10,600	32			
6,5x3	ang.est. toro	1,350	40			
12x20	finale	4,850	10			
1,2x20	ang.est.finale	1,700	40			
8x20	gemme	8,000	30			
6,5x20	square	8,000	30			
20x20	zoccolo	13,160	16			
2,2x20	ang.est.zoccolo	1,950	30			
1,2x20	coprispigolo	0,720	21			
Electa						
20x80	Electa	12,650	5	0,80	42	531,30
5,6x20	toro	10,600	32			
5,6x2,5	ang.est. toro	1,350	40			
12x20	finale	4,850	10			
10x3	ang.est.finale	1,800	40			
20x20	zoccolo	13,200	16			
2x20	ang.est.zoccolo	1,950	30			

Epoque

Epoque, decorazione e struttura. Bicottura in pasta bianca da rivestimento con finitura sia matt che lucida craquelé. Costituita da 3 tipi di decori ben distinti: barocco, liberty, classico, proposti in diverse colorazioni classiche vittoriane.

Epoque, decoration and texture. Double fired white body wall tile in a matt or craquele finish. Consisting of 3 decor styles - baroque, Art Nouveau and classic and available in traditional Victorian colours.



Designed by Tatiana Zhuravleva interior designer

Ivory Craquelé

20x80 Epoque Medici Ivory Craquelé - 12x20 Epoque Terminale Pitti Ivory Craquelé





Ivory Craquelé

Rivestimenti/Wall:

- 20x80 Epoque Medici Ivory Craquelé
- 12x20 Epoque Terminale Pitti Ivory Craquelé
- 12x2 Epoque Angolo Terminale Pitti Ivory Craquelé
- 20x20 Epoque Zoccolo Ivory Craquelé
- 20x2 Epoque Ang.zoccolo Ivory Craquelé
- 1.2x20 Epoque Coprispigolo Ivory Craquelé
- 10x20 Vintage Ivory Glossy

Pavimento/Floor:

- 30x30 Brera Sale
- 30x30 Brera Carbone

Caramel Craquelé

Rivestimenti/Wall:

20x80 Epoque Belvedere Caramel Craquelé

12x20 Epoque Terminale Deco Caramel Craquelé

20x20 Epoque Zoccolo Caramel Craquelé

Pavimento/Floor:

20x20 Old England Dover

33,7x33,7 Brera Mosaico - 4x4 Brera Mix Sale Carbone







Mustard Craquelé

Rivestimenti/Wall:

20x80 Epoque Hermitage Mustard Craquelé - 6.5x20 Epoque Finale Mustard Craquelé - 6.5x2 Ang. Epoque Finale Mustard Craquelé - 20x20 Epoque Zoccolo Mustard Craquelé - 20x2 Epoque Ang.zoccolo Mustard Craquelé - 1.2x20 Epoque Coprispigolo Mustard Craquelé

Special Pieces



Finale
6,5x20 cm

1



Angolo finale
2x6,5cm

2



Coprispigolo
1,2x20

3



Zoccolo
20x20

4



Ang. Zoccolo
2x20

5

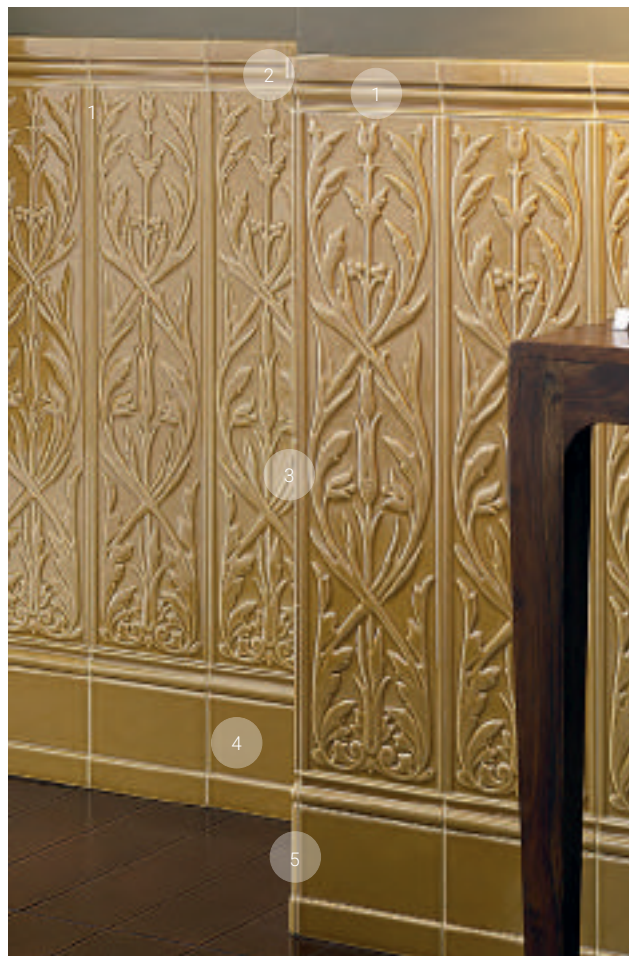
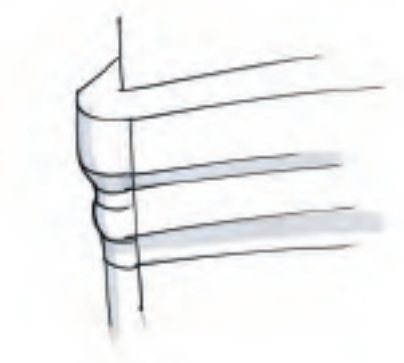

Epoque Matt

Formato 20x80 / Size 20x80 7,87x31,50"

Spessore: ca. 9,5/11 mm / Thickness: ca. 10,37/0,43
52 Price List (pz)

Belvedere + Medici + Hermitage



Belvedere
Bianco Matt
BEL1

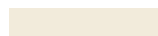

Belvedere
Ivory Matt
BEL10



Medici
Bianco Matt
MED1

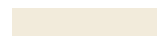

Medici
Ivory Matt
MED10

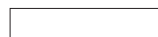

Hermitage
Bianco Matt
HER1

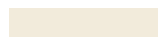

Hermitage
Ivory Matt
HER10

Pezzi speciali / Special pieces

Finale*

6,5x20 cm - 2,56x7,87 "

105 Price List (pz)



Ang. Finale*

2x6,5 cm - 0,79x2,56 "

72 Price List (pz)



Terminale Decò*

12x20 cm - 4,72x7,87 "

58 Price List (pz)

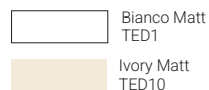

Ang. Term. Decò*

2x12 cm - 0,79x4,72 "

40 Price List (pz)

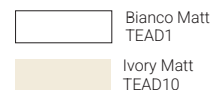

Terminale Pitti*

12x20 cm - 4,72x7,87 "

58 Price List (pz)



Ang. Term. Pitti*

2x12 cm - 0,79x4,72 "

40 Price List (pz)

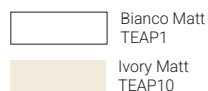

Zoccolo

20x20 cm - 7,87x7,87 "

105 Price List (pz)



Ang. Zoccolo

2x20 cm - 0,79x7,87 "

73 Price List (pz)

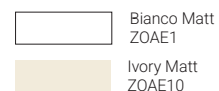

Coprispigolo

1,2x20 cm - 0,47x7,87 "

19 Price List (pz)

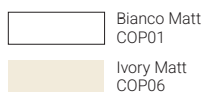

* Pezzi smaltati su lato superiore / Pieces glazed on top

Epoque Craquelé

Formato 20x80 / Size 20x80 7,87x31,50"

Spessore: ca. 9,5/11 mm / Thickness: ca. 0,37/0,43
52 Price List (pz)

Belvedere + Medici + Hermitage

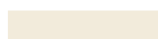

Belvedere
Ivory Craquelé
BEL2



Belvedere
Grey Craquelé
BEL4



Belvedere
Bianco Craquelé
BEL5



Belvedere
Bottle Craquelé
BEL6



Belvedere
Caramel Craquelé
BEL7



Belvedere
Mustard Craquelé
BEL8



Belvedere
Cobalt Craquelé
BEL9

Si consiglia di trattare gli smalti
craquelé con impregnante prima
della stuccatura.
*We suggest to treat the crackle
glazes with appropriate sealer
before grouting.*

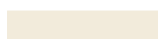

Medici
Ivory Craquelè
MED2



Medici
Grey Craquelè
MED4



Medici
Bianco Craquelè
MED5



Medici
Bottle Craquelè
MED6



Medici
Caramel Craquelè
MED7



Medici
Mustard Craquelè
MED8



Medici
Cobalt Craquelè
MED9

Epoque Craquelé

Formato 20x80 / Size 20x80 7,87x31,50"

Spessore: ca. 9,5/11 mm / Thickness: ca. 0,37/0,43
52 Price List

Belvedere + Medici + Hermitage

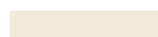

Hermitage
Ivory Craquelé
HER2



Hermitage
Grey Craquelé
HER4



Hermitage
Bianco Craquelé
HER5



Hermitage
Bottle Craquelé
HER6



Hermitage
Caramel Craquelé
HER7



Hermitage
Mustard Craquelé
HER8



Hermitage
Cobalt Craquelé
HER9

Pezzi speciali / Special pieces

Finale*

6,5x20 cm - 2,56x7,87"
105 Price List (pz)



-  Ivory Craq. FIE2
-  Grey Craq. FIE4
-  Bianco Craq. FIE5
-  Bottle Craq. FIE6
-  Caramel Craq. FIE7
-  Mustard Craq. FIE8
-  Cobalt Craq. FIE9

Ang. Finale*

2x6,5 cm - 0,79x2,56"
72 Price List (pz)









-  Ivory Craq. FIAE2
-  Grey Craq. FIAE4
-  Bianco Craq. FIAE5
-  Bottle Craq. FIAE6
-  Caramel Craq. FIAE7
-  Mustard Craq. FIAE8
-  Cobalt Craq. FIAE9

Terminale Decò*

12x20 cm - 4,72x7,87"
58 Price List (pz)



-  Ivory Craq. TED2
-  Grey Craq. TED4
-  Bianco Craq. TED5
-  Bottle Craq. TED6
-  Caramel Craq. TED7
-  Mustard Craq. TED8
-  Cobalt Craq. TED9

Ang. Term. Decò*

2X12 cm - 0,79x4,72"
40 Price List (pz)



-  Ivory Craq. TEAD2
-  Grey Craq. TEAD4
-  Bianco Craq. TEAD5
-  Bottle Craq. TEAD6
-  Caramel Craq. TEAD7
-  Mustard Craq. TEAD8
-  Cobalt Craq. TEAD9

Terminale Pitti*

12x20 cm - 4,72x7,87"
58 Price List (pz)



-  Ivory Craq. TEP2
-  Grey Craq. TEP4
-  Bianco Craq. TEP5
-  Bottle Craq. TEP6
-  Caramel Craq. TEP7
-  Mustard Craq. TEP8
-  Cobalt Craq. TEP9

Ang. Term. Pitti*

2x12 cm - 0,79x4,72"
40 Price List (pz)



-  Ivory Craq. TEAP2
-  Grey Craq. TEAP4
-  Bianco Craq. TEAP5
-  Bottle Craq. TEAP6
-  Caramel Craq. TEAP7
-  Mustard Craq. TEAP8
-  Cobalt Craq. TEAP9

Zoccolo

20x20 cm - 7,87x7,87"
105 Price List (pz)



-  Ivory Craq. ZOE2
-  Grey Craq. ZOE4
-  Bianco Craq. ZOE5
-  Bottle Craq. ZOE6
-  Caramel Craq. ZOE7
-  Mustard Craq. ZOE8
-  Cobalt Craq. ZOE9

Ang. Zoccolo

2x20 cm - 0,79x7,87"
73 Price List (pz)



-  Ivory Craq. ZOAE2
-  Grey Craq. ZOAE4
-  Bianco Craq. ZOAE5
-  Bottle Craq. ZOAE6
-  Caramel Craq. ZOAE7
-  Mustard Craq. ZOAE8
-  Cobalt Craq. ZOAE9

Coprispigolo

1,2x20 cm - 0,47x7,87"
19 Price List (pz)



-  Ivory Craq. COE2
-  Grey Craq. COE4
-  Bianco Craq. COP05
-  Bottle Craq. COE6
-  Caramel Craq. COE7
-  Mustard Craq. COE8
-  Cobalt Craq. COE9

* Pezzi smaltati su lato superiore / Pieces glazed on top

Si consiglia di trattare gli smalti craquelé con impregnante prima della stuccatura.
We suggest to treat the crackle glazes with appropriate sealer before grouting.

Epoque



Caramel Craquelé

Rivestimenti/Wall:

20x80 Epoque Belvedere Caramel Craquelé - 12x20 Epoque Terminale Deco Caramel Craquelé - 20x20 Epoque Zoccolo Caramel Craquelé

Lista imballaggi per box / Packing list for box

Descrizione / Description		kg box	pz.box	mq box	box pallet	kg. pallet
20x80	Formato 20x80 Belvedere	12,65	5	0,80	42	531,30
20x80	Formato 20x80 Hermitage	12,65	5	0,80	42	531,30
20x80	Formato 20x80 Medici	12,65	5	0,80	42	531,30
6,5x20	Finale	11,55	32	-	-	-
2x6,5	Angolo Finale	1,60	40	-	-	-
12x20	Terminale	4,00	10	-	-	-
2x12	Angolo Terminale	1,50	30	-	-	-
20x20	Zoccolo	13,20	16	-	-	-
2x20	Angolo Zoccolo	1,95	30	-	-	-
1,2x20	Coprispigolo	0,85	21	-	-	-

Gres Porcellanato

Porcelain Stoneware











11 colori, 6 formati, 5 pezzi speciali per pose e finiture, infinite combinazioni di mosaici su rete 2,3x2,3 e 4x4, decorazioni serigrafiche sia sui fondi che sui pezzi speciali. Inoltre la superficie R10 rende questi prodotti adatti anche per ambienti commerciali. Tutte queste soluzioni progettuali definiscono il mondo creativo del Gres Porcellanato Made in Grazia. La storica collezione Old England si fonde con Pitti in uniformità di stile, dando vita a Brera, per esaltare le potenzialità creative di entrambe. In questa collezione, il formato 30x30 si combina con ottagononi, listelli e tozzetti, lasciando spazio all'immaginazione e alla creazione di ambienti unici e sorprendenti.

11 colors, 6 sizes, 5 special pieces for installation and finishing, endless combinations of 2.3x2.3 and 4x4 mesh-backed mosaics, silk-screen decorations on both tiles and special pieces. Furthermore, the R10 surface makes these products suitable also for commercial environments. All these design solutions define the creative world of Porcelain Stoneware Made in Grazia. The historic Old England collection merges with Pitti in a uniform style, giving birth to Brera, to enhance the creative potentials of both. In this collection, the 30x30 size is combined with octagons, listels and tozzettos, leaving room for imagination and the creation of unique and surprising environments.

Porcelain Stoneware











Wall and floor

Codici colore / Color Codes

	Brera 30x30 cm 11,81x11,81"	Brera Ottagono 30x30 cm 11,81x11,81"	Brera 15x30 cm 5,91x11,81"	Pitti 30x30 cm 11,81x11,81"	Old England 20x20 cm 7,87x7,87"	Old England Ottagono 20x20 cm 7,87x7,87"
 Sale/ Dover	ERA1	OTERA1	ERAS1	PIT1	OE1	OE01
 Carbone/ York	ERA2	OTERA2	ERAS2	PIT2	OE5	OE05
 Cielo/ Bristol	ERA3	OTERA3	ERAS3	PIT3	OE8	OE08
 Salvia/ Bath	ERA4	OTERA4	ERAS4	PIT4	OE4	OE04
 Tortora	ERA5	OTERA5	ERAS5	PIT5		
 Cemento/ Oxford	ERA6	OTERA6	ERAS6	PIT6	OE7	OE07
 Menta	ERA7	OTERA7	ERAS7	PIT7		
 Senape/ Leeds	ERA8	OTERA8	ERAS8	PIT8	OE2	OE02
 Cotto/ Chester	ERA9	OTERA9	ERAS9	PIT9	OE3	OE03
 Sabbia	ERA11	OTERA11	ERAS11	PIT10		
 London					OE6	OE06

Pezzi speciali / Special pieces

Codici colore / Color Codes

	Tozzetto 4x4 cm 1,57x1,57"	Tozzetto 7,3x7,3 cm 2,87x2,87"	Listello 7,3x30 cm 2,87x11,81"	Tozzetto 12,3x12,3 cm 4,84x4,84"	Zoccolo 10x20 cm 3,94x7,87"
 Sale/ Dover	TOE1	LERA1	LTERA1	TPI1	OEZ1
 Carbone/ York	TOE5	LERA2	LTERA2	TPI2	OEZ5
 Cielo/ Bristol	TOE8	LERA3	LTERA3	TPI3	OEZ8
 Salvia/ Bath	TOE4	LERA4	LTERA4	TPI4	OEZ4
 Tortora	TOE50	LERA5	LTERA5	TPI5	
 Cemento/ Oxford	TOE7	LERA6	LTERA6	TPI6	OEZ7
 Menta	TOE70	LERA7	LTERA7	TPI7	
 Senape/ Leeds	TOE2	LERA8	LTERA8	TPI8	OEZ2
 Cotto/ Chester	TOE3	LERA9	LTERA9	TPI9	OEZ3
 Sabbia	TOE11	LERA11	LTERA11	TPI10	
 London	TOE6				OEZ6

Brera

Gres porcellanato tutta massa con superficie R10, adatto sia agli ambienti residenziali che a quelli commerciali. Una rivisitazione di un grande classico della posa che proviene dal marmo, in ogni ambiente riesce a conferire eleganza, design e allo stesso tempo contemporaneità per i suoi colori moderni. I mosaici della collezione Brera, disponibili con tessere da 4x4, 2,4x2,4 e 7,3x7,3 - 2,4x2,4 possono essere composti in ogni colore della gamma nei diversi schemi di posa del foglio del mosaico proposti nei diversi colori senza quantità minime. Realizziamo internamente e a mano ogni mosaico, rispettando la nostra tradizione e l'artigianalità che da sempre ci contraddistingue.

Full body porcelain stoneware with R10 surface, suitable for both residential and commercial environments. A new interpretation of a laying great classic that comes from marble; it manages to give at the same time elegance, design and contemporaneity in any location for its modern colors. The mosaics of the Brera collection, available with 4x4, 2,4x2,4 and 7,3x7,3 - 2,4x2,4 tiles, can be composed in any color of the range in the different mosaic sheet. Thanks to the variety of colors and finishes available, each surface can be transformed into a unique project, perfectly suitable for any style, from classic to contemporary.



Salvia - Carbone

Pavimento/Floor:
15x30 Brera Salvia - 7,3x7,3 Brera Tozzetto Listello Carbone





Sale - Salvia

Pavimento/Floor:

Mosaico Brera Tessere 7,3x7,3 Sale + 2,4x2,4 Salvia

Sale - Carbone

Pavimento/Floor:
30x30 Brera Milano Carbone + Cemento

Rivestimenti/Wall:
12x20 Boiserie Origins Finale Carbone Matt
20x80 Boiserie Origins Boiserie Carbone Matt
20x20 Boiserie Origins Zoccolo Carbone Matt







Sale - Salvia - Menta

Pavimento/Floor:
30x30 Brera Milano Salvia + Menta



Cemento - Sale - Cotto

Pavimento/Floor:

30x30 Brera Cemento - 7,3x30 Brera Listello Sale - 7,3x7,3 Brera Tozzetto Listello Cotto

Sale - Carbone

Pavimento/Floor:

31,5x31,5 Brera Mosaici Sale Carbone - 2,4x2,4 Brera Diagonal, Shapes, Bi-Rhombus

33,7x33,7 Brera Mosaici Sale Carbone - 4x4 Punto, Continua





Brera

Formato 30x30 / Size 30x30 11,81x11,81"

Spessore: ca. 8 mm / Thickness: ca. 0,3
 Gres porcellanato tutta massa R10 / Full-body porcelain stoneware, R10
 132 Price List (mq) Cielo - 83 Price List (mq) All Other Colors

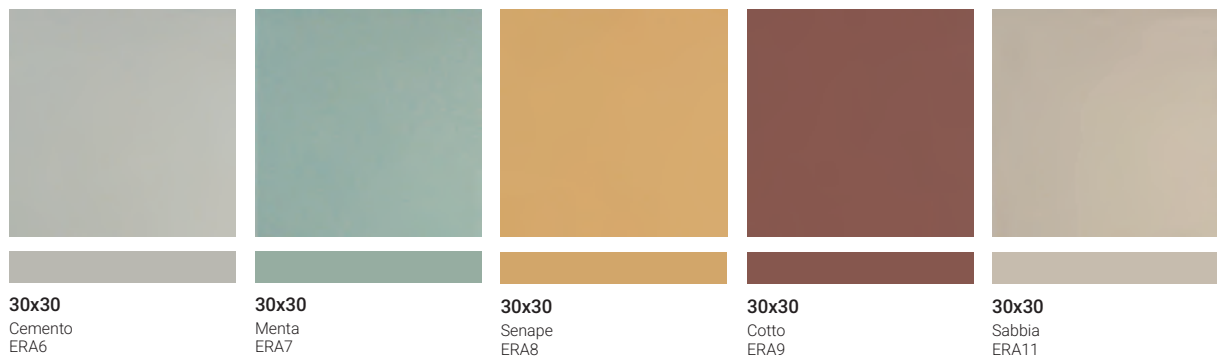
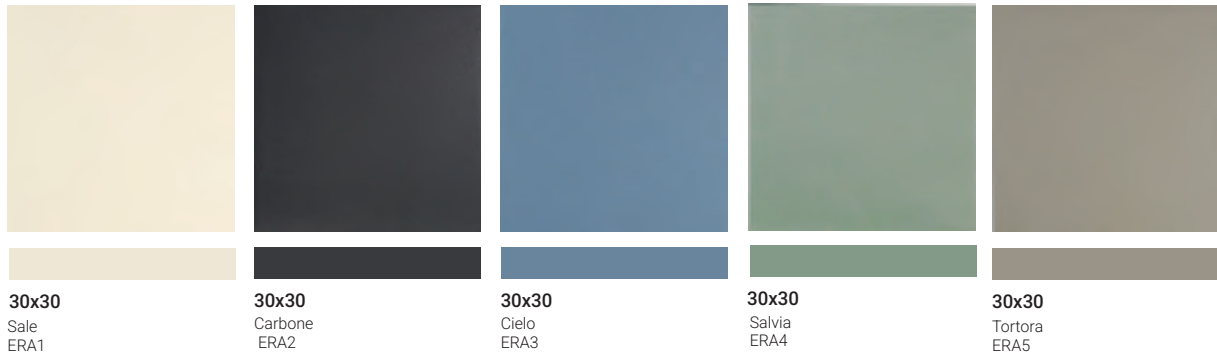

Formato Ottagono 30X30 / Size Ottagono 30x30 11,81x11,81"

Spessore: ca. 8 mm / Thickness: ca. 0,3
 Gres porcellanato tutta massa R10 / Full-body porcelain stoneware, R10
 130 Price List (mq) Cielo - 132 Price List (mq) All Other Colors

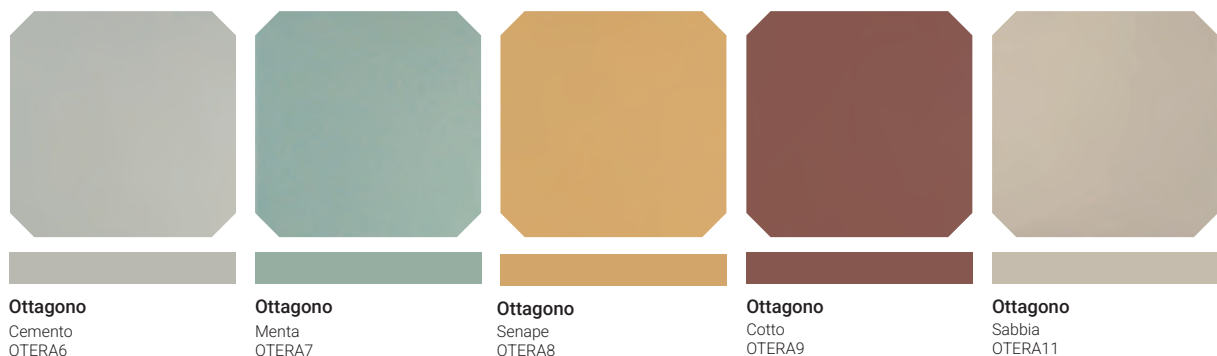
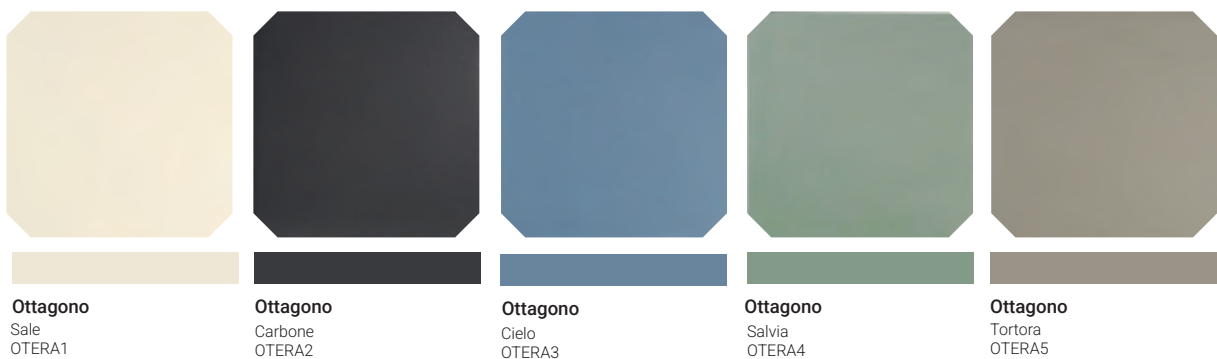





















Formato 15x30 / Size 15x30 5,91x11,81"

Spessore: ca. 8 mm / Thickness: ca. 0,3
 Gres porcellanato tutta massa R10 / Full-body porcelain stoneware, R10
 108 Price List (mq) Cielo - 93 Price List (mq) All Other Colors

				
				
Small Sale ERAS1	Small Carbone ERAS2	Small Cielo ERAS3	Small Salvia ERAS4	Small Tortora ERAS5
				
				
Small Cemento ERAS6	Small Menta ERAS7	Small Senape ERAS8	Small Cotto ERAS9	Small Sabbia ERAS11

Formato Tozzetto 4x4 / Size Tozzetto 4x4 1,57x1,57"

Spessore: ca. 8 mm / Thickness: ca. 0,3
 Gres porcellanato tutta massa R10 / Full-body porcelain stoneware, R10
 38 Price List (pz) Cielo 8 Price List (pz) All Other Colors

				
				
Tozzetto Sale TOE1	Tozzetto Carbone TOE5	Tozzetto Cielo TOE8	Tozzetto Salvia TOE4	Tozzetto Tortora TOE50
				
				
Tozzetto Cemento TOE7	Tozzetto Menta TOE70	Tozzetto Senape TOE2	Tozzetto Cotto TOE3	Tozzetto Sabbia TOE11

Brera

Formato Listello 7,3x30 / Size 7,3x30 2,87x11,81"

Spessore: ca. 8 mm / Thickness: ca. *0,3
Gres porcellanato tutta massa R10 / Full-body porcelain stoneware, R10
67 Price List (pz) Cielo - 64 Price List (pz) All Other Colors

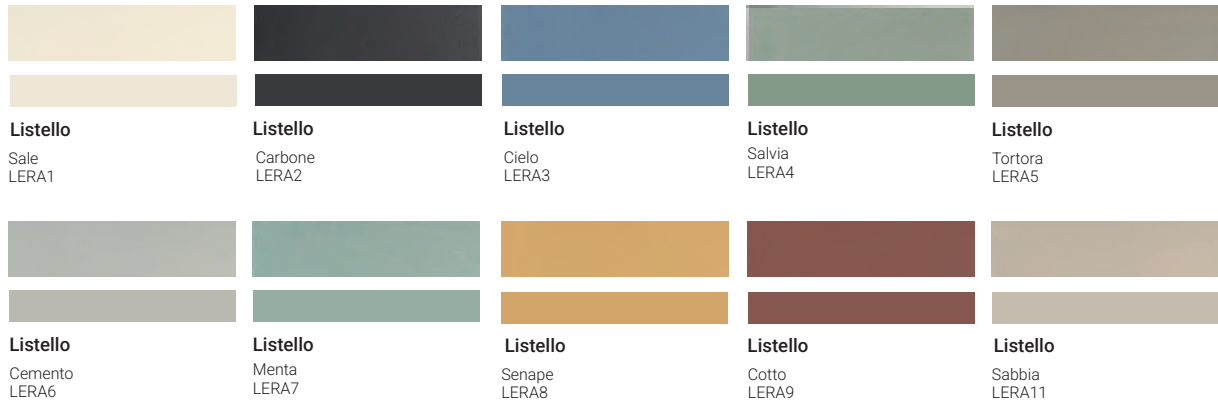

Formato Tozzetto Listello 7,3x7,3 / Size Tozzetto Listello 7,3x7,3 2,87x2,87"

Spessore: ca. 8 mm / Thickness: ca. *0,3
Gres porcellanato tutta massa R10 / Full-body porcelain stoneware, R10
64 Price List (Pz) Cielo - 63 Price List (Pz) All Other Colors

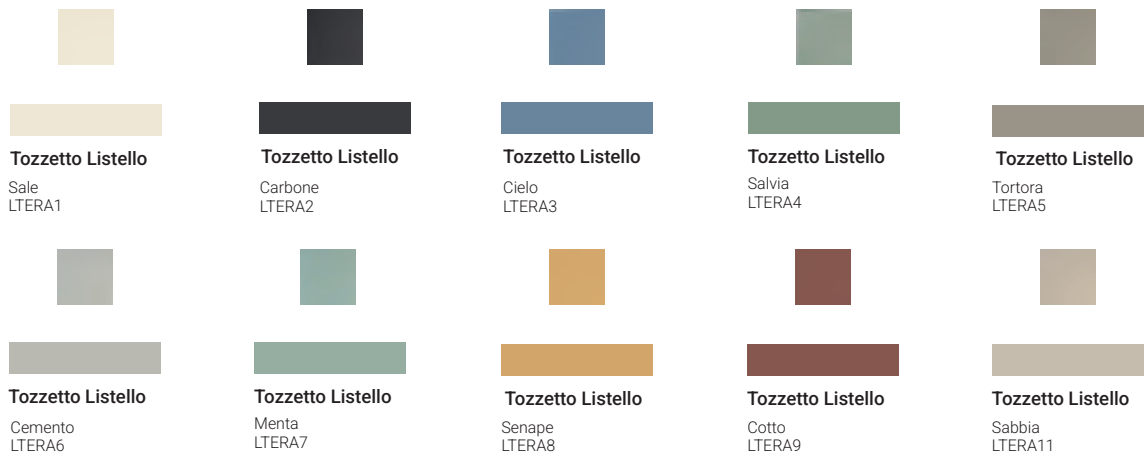

Decoro/ Decoration

Spessore: ca. 8 mm / Thickness: ca. *0,3

Milano

30x30 cm - 2,87x2,87"
135 Price List (mq)

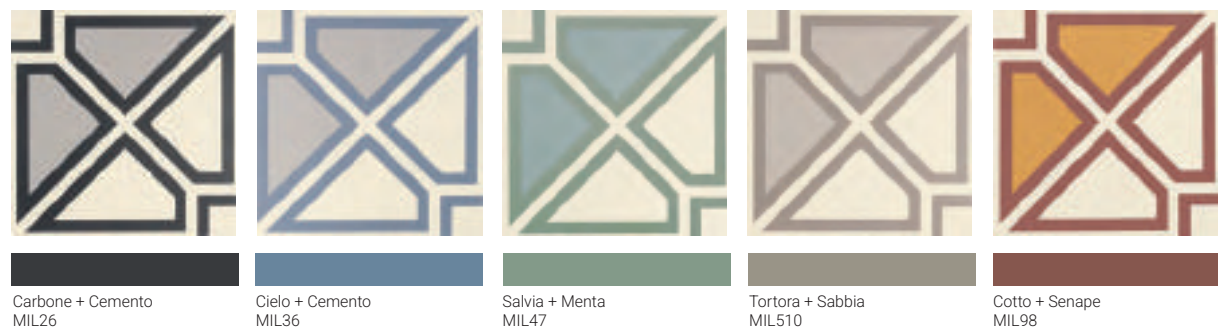

Mosaico tessere 4x4 / Sheet mosaic tiles 4x4

33,7x33,7 cm - 13,27x13,27"

46 Price List (pz) Cielo 29 Price List (pz) All Other Colors

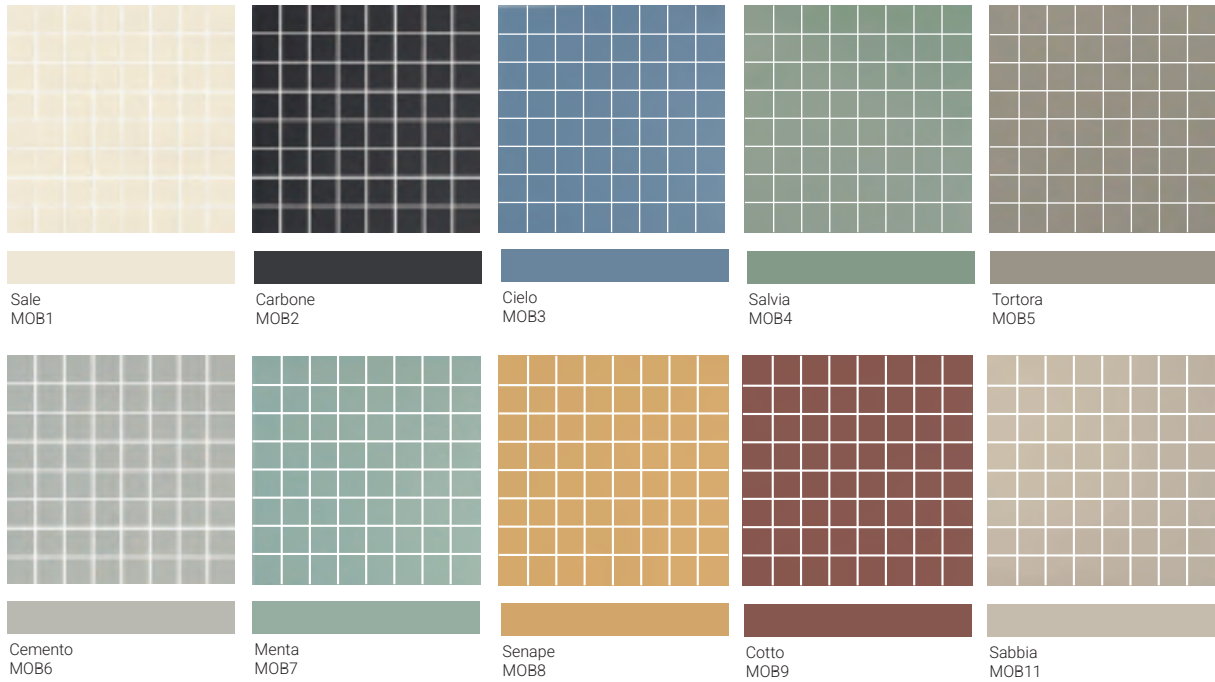

Mosaico tessere 2,4x2,4 / Sheet mosaic tiles 2,4x2,4

31,5x31,5 cm - 12,40x12,40"

90 Price List (pz) Cielo 59 Price List (pz) All Other Colors

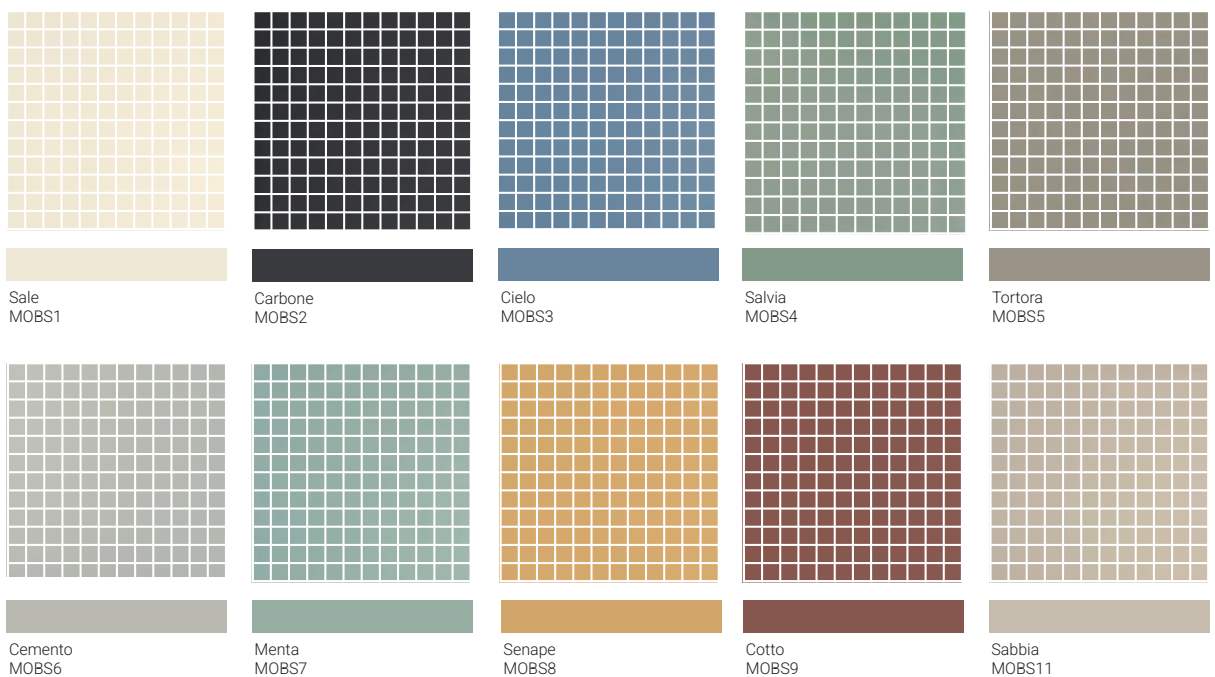

Brera

Schemi di posa mosaici / Mosaics laying patterns

Mosaico tessere 4x4 / Sheet mosaic tiles 4x4

33,7x33,7 cm - 13,27x13,27"

29 Price List (pz)

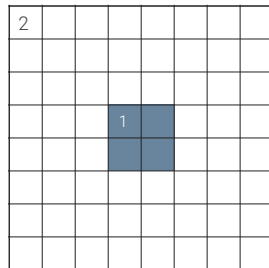

Indica nell'ordine i colori con cui vuoi creare il tuo mosaico scegliendoli dalla gamma colori.

Indicate in order the colours with which you want create your mosaic, choosing them from the colours range.

Esempio di ordine MOB4PU: col. 1 Cielo, col. 2 Sale

Order example MOB4PU: col 1 Cielo, col 2 Sale

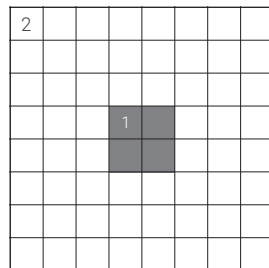

4X4 punto - MOB4PU

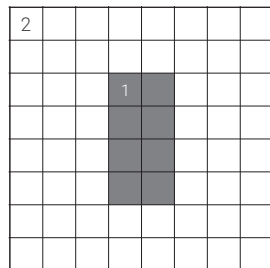

4X4 doppio - MOB4DO

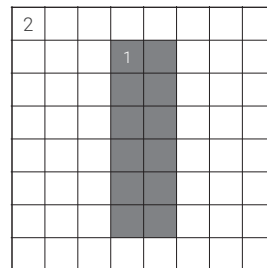

4X4 linea - MOB4LI

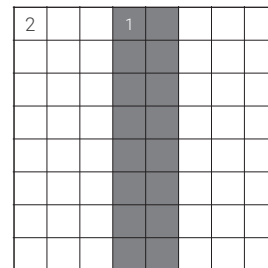

4X4 continua - MOB4CO

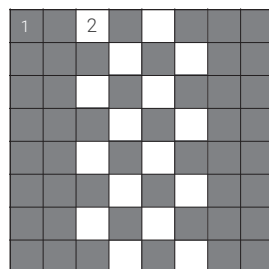

4X4 pista - MOB4PI

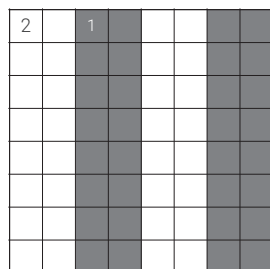

4X4 bande - MOB4BA

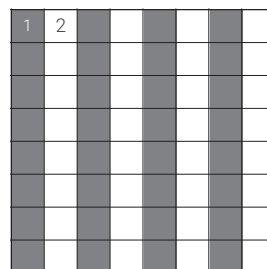

4X4 righe - MOB4RI

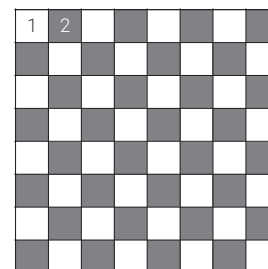

4X4 MIX - MOB4MI

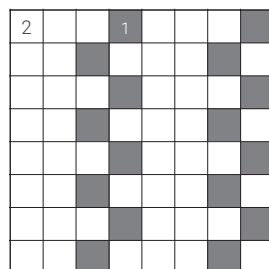

4X4 quadri - MOB4QU

Mosaico tessere 2,4x2,4 / Sheet mosaic tiles 2,4x2,4

31,5x31,5 cm - 12,40x12,40"

59 Price List (pz)

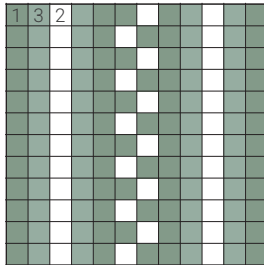

Indica nell'ordine i colori con cui vuoi creare il tuo mosaico scegliendoli dalla gamma colori.

Indicate in order the colours with which you want create your mosaic, choosing them from the colours range.

Esempio di ordine MOB2RA: col 1 Salvia, col 2 Sale, col 3 Menta
Order example MOB2RA: col 1 Salvia, col 2 Sale, col 3 Menta

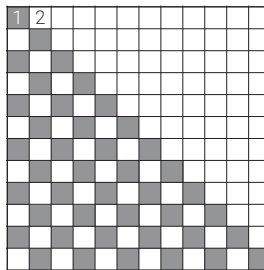

2,4x2,4 diagonal - MOB2DI

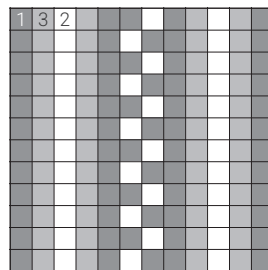

2,4x2,4 race - MOB2RA

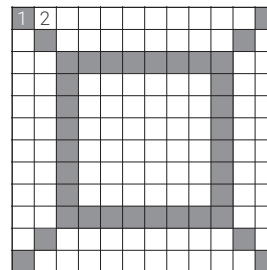

2,4x2,4 shapes - MOB2SH

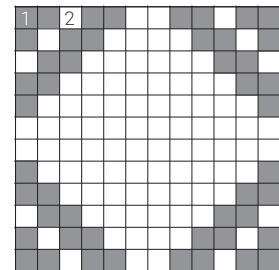

2,4x2,4 rombus - MOB2RH

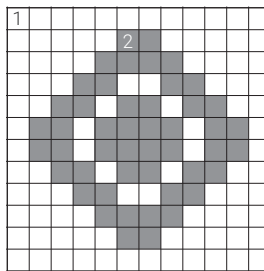

2,4x2,4 bi-rhombus - MOB2BI

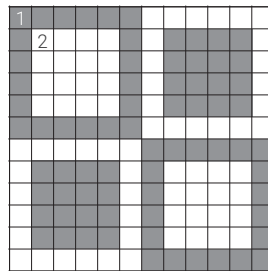

2,4x2,4 square - MOB2SQ

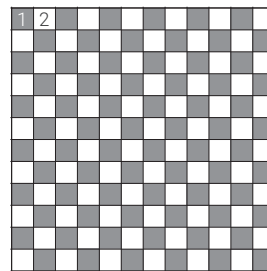

2,4x2,4 mix - MOB2MI

Mosaico tessere 7,3x7,3+2,4x2,4 / Sheet mosaic tiles 7,3x7,3+2,4x2,4

Approx. 30x30 cm - 11,81"x11,81"

29 Price List (pz)

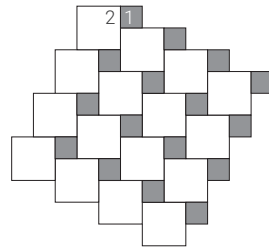
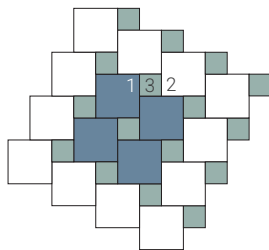

7,3x7,3 - 2,4x2,4 tozzetti MOB7TO

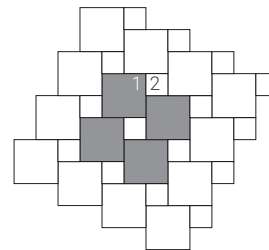

7,3x7,3 - 2,4x2,4 fiore MOB7FI

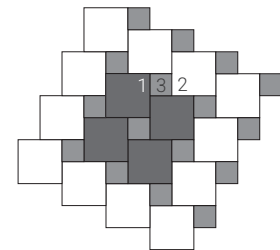

7,3x7,3 - 2,4x2,4 colori MOB7CO

Indica nell'ordine i colori con cui vuoi creare il tuo mosaico scegliendoli dalla gamma colori.

Indicate in order the colours with which you want create your mosaic, choosing them from the colours range.

Esempio di ordine MOB7CO: col. 1 Cielo, col. 2 Sale, col. 3 Menta
Order example MOB7CO: col. 1 Cielo, col. 2 Sale, col. 3 Menta

Brera



Sale - Carbone

Pavimento/Floor

31,5x31,5 Brera Mosaici Sale Carbone - 2,4x2,4 Diagonal, Shapes, Bi-Rhombus

33,7x33,7 Brera Mosaici Sale - Carbone - 4x4 Punto, Continua

La posa senza fughe è fortemente sconsigliata in quanto si tratta di gres porcellanato tutta massa non rettificato. Addirittura non praticabile per ambienti esterni. Consigliamo fughe di almeno 3 mm, così come prescritto dalle diverse norme di posa (in Italia UNI 11493).
Laying edge-to-edge without joints is strongly discouraged, indeed it is not practicable for external applications.
We recommend joints of at least 3 mm, according to the different laying standards (in Italy, UNI 11493).

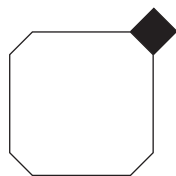

30x30
Ottagono

Posa: 1 pezzo 30x30 ottagonno, 1 pezzo 4x4 tozzetto
 Pezzi a m2: 11,1 pz 30x30 ottagonno - 11,1 pz 4x4 tozzetto
 Installation: 1 pc 30x30 ottagonno, 1 pc 4x4 tozzetto
 Pieces x m2: 11,1 pcs 30x30 ottagonno - 11,1 pcs 4x4 tozzetto
 Gres porcellanato tutta massa
 Full body porcelain stoneware

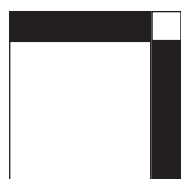

30x30
7,3x30
7,3x7,3

Modulo posa cassettone formato da: 2 listelli 7,3x30, 1 tozzetto lis. 7,3x7,3, 1 30x30 = m2 0,133
 Pezzi a m2: 7,5 pz 30x30 - 7,5 pz 7,3x7,3 tozz lis. - 15 pz 7,3x30 listelli
 È possibile che si riscontrino differenze di calibro tra i listelli e il 30x30, è necessario aggiustare in posa.
 Fuga consigliata di almeno 3 mm.
 Installation module: 2 listelli 7,3x30, 1 tozzetto lis. 7,3x7,3, 1 30x30 = m2 0,133
 Pieces x m2: 7,5 pcs 30x30 - 7,5 pcs 7,3x7,3 tozz lis. - 15 pcs 7,3x30 listelli
 It might be possible to find differences in caliber between 7,3x30 listelli and the 30x30, if necessary, adjust during installation. Use at least a 3 mm grout joint.

Lista imballaggi per box / Packing list for box

Descrizione / Description		kg box	pz. box	mq box	box pallet	kg pallet
30x30	Formato 30x30	24,64	15	1,35	40	984
30x30	Formato Ottagono 30x30	24,09	15	1,33	40	963
30x30	Milano	24,60	15	1,35	40	984
15x30	Formato 15x30	24,60	30	1,35	40	984
4x4	Formato Tozzetto 4x4	8	280	-	-	-
7,3x30	Formato Listello 7,3x30	15,03	36	-	-	-
7,3x7,3	Formato Tozzetto Listello 7,3x7,3	6,95	70	-	-	-
Mosaico tessere 4x4	Foglio 33,7x33,7	11,85	6	-	-	-
Mosaico tessere 2,4x2,4	Foglio 31,5x31,5	9,80	6	-	-	-
Mosaico tessere 7,3x7,3 - 2,4x2,4	Foglio approssimativamente 30x30	10,40	6	-	-	-

Pitti

Gres porcellanato tutta massa con superficie R10, adatto a tutti gli ambienti. La serie Pitti si distingue per la sua straordinaria versatilità, grazie a una palette cromatica accuratamente studiata per armonizzarsi con ogni stile d'interno. Gli ottagononi e i tozzetti, disponibili in versioni a tinta unita o decorati, si combinano tra loro in un gioco di colori e contrasti che esalta i dettagli di ogni spazio.

Full-body porcelain stoneware with R10 surface, suitable for all environments. The Pitti series stands out for its extraordinary versatility, thanks to a chromatic palette carefully designed to suit every interior style. The octagons and tozzetti, available in plain or decorated colours, are combined in a play of colours and contrasts that enhances the details of each space.



Multicolor

Pavimento/Floor:
30x30 Pitti Ottagono - 12.2x12.2 Pitti Tozzetto



Sabbia- Tortora

Pavimento/Floor:
30x30 Pitti Ottagono A Sabbia + Tortora - 12.2x12.2 Pitti Tozzetto Sabbia



Salvia

Pavimento/Floor:
30x30 Pitti Ottagono Salvia - 12.2x12.2 Pitti Tozzetto Salvia



Sale - Cielo

Pavimento/Floor:
30x30 Pitti Ottagono A Sale + Cielo - 12.2x12.2 Pitti Tozzetto Sale - 34.5x34.5 Mosaico Signoria Sale



Sale - Cielo

Pavimento/Floor:
34.5x34.5 Pitti Mosaico Uffizi Cielo + Sale



Senape - Tortora

Pavimento/Floor:
30x30 Pitti Ottagono Senape - 12.2x12.2 Pitti Tozzetto Tortora



Menta - Sale

Pavimento/Floor:
30x30 Pitti Ottagono Menta - 12.2x12.2 Pitti Tozzetto A Sale + Menta





Sale - Carbone

Pavimento/Floor:
30x30 Pitti Ottagono B Sale + Carbone
12.2x12.2 Pitti Tozzetto Sale
30x30 Brera Carbone

Pitti

Formato Ottagono 30X30 / Size Ottagono 30x30 11,81x11,81"

Spessore: ca. 8 mm / Thickness: ca. 0,3
 Gres porcellanato tutta massa R10 / Full-body porcelain stoneware, R10
 130 Price List (mq) Cielo - 132 Price List (mq) All Other Colors

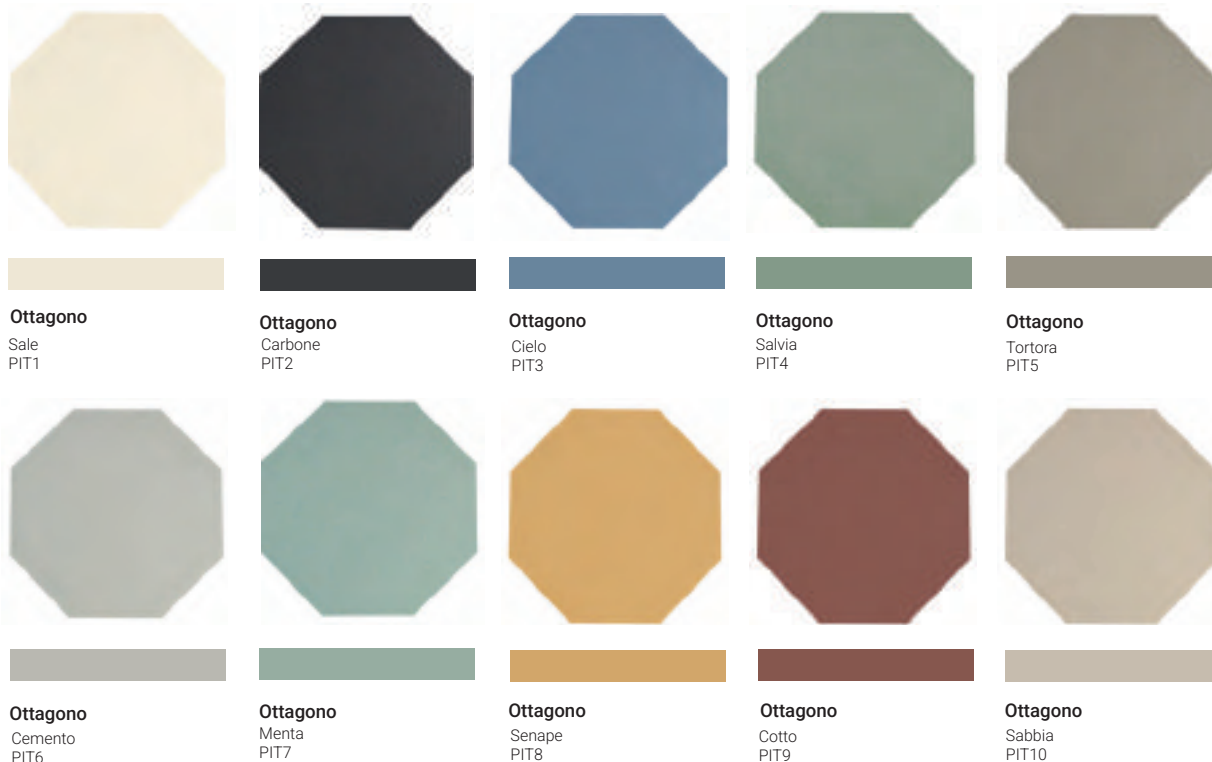

Formato Tozzetto 12,2x12,2 /
Size Tozzetto 12,2x12,2 4,80x4,80"

Spessore: ca. 8 mm / Thickness: ca. 0,3
 Gres porcellanato tutta massa R10 / Full-body porcelain stoneware, R10
 67 Price List (mq) Cielo - 64 Price List (mq) All Other Colors

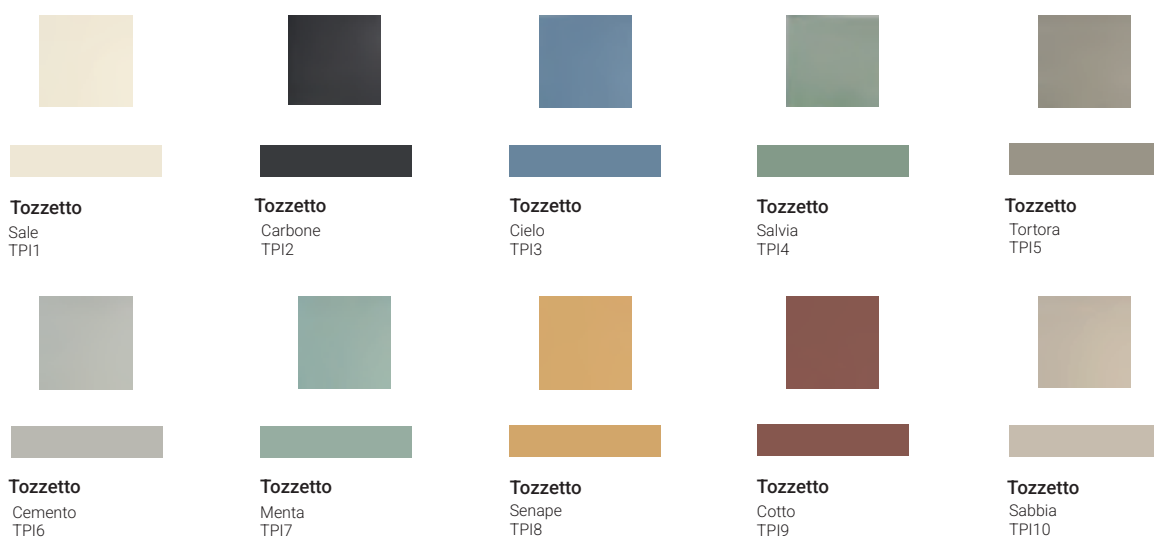

Decoro Ottagono A 30X30 /
Decoration Ottagono A 30x30 11,81x11,81"

Spessore: ca. 8 mm / Thickness: ca. 0,3
 108 Price List (mq)



Ottagono A
 Sale + Carbone
 PIT26A

Ottagono A
 Sale + Cielo
 PIT13A

Ottagono A
 Menta + Salvia
 PIT74A

Ottagono A
 Sale + Menta
 PIT17A

Ottagono A
 Senape+ Cotto
 PIT89A



Ottagono A
 Sabbia + Tortora
 PIT105A

Decoro Tozzetto A 12,2x12,2 /
Decoration Tozzetto A 12,2x12,2 4,80x4,80"

Spessore: ca. 8 mm / Thickness: ca. 0,3
 80 Price List (pz)

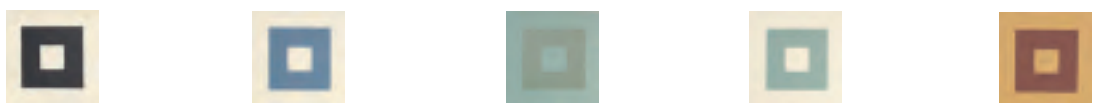

Tozzetto A
 Sale + Carbone
 TPI26A

Tozzetto A
 Sale + Cielo
 TPI13A

Tozzetto A
 Menta + Salvia
 TPI74A

Tozzetto A
 Sale + Menta
 TPI17A

Tozzetto A
 Senape+ Cotto
 TPI89A



Tozzetto A
 Sabbia + Tortora
 TPI105A

Decoro Ottagono B 30X30 /
Decoration Ottagono B 30x30 11,81x11,81"

Spessore: ca. 8 mm / Thickness: ca. *0,3
 108 Price List (mq)



Ottagono B

Sale + Carbone
 PIT26B



Ottagono B

Sale + Cielo
 PIT13B



Ottagono B

Menta + Salvia
 PIT74B



Ottagono B

Sale + Menta
 PIT17B



Ottagono B

Senape + Cotto
 PIT89B



Ottagono B

Sabbia + Tortora
 PIT105B

Decoro Tozzetto B 12,2x12,2 /
Decoration Tozzetto B 12,2x12,2 4,80x4,80"

Spessore: ca. 8 mm / Thickness: ca. *0,3
 80 Price List (pz)



Tozzetto B

Sale + Carbone
 TPI26B



Tozzetto B

Sale + Cielo
 TPI13B



Tozzetto B

Menta + Salvia
 TPI74B



Tozzetto B

Sale + Menta
 TPI17B



Tozzetto B

Senape+ Cotto
 TPI89B



Tozzetto B

Sabbia + Tortora
 TPI105B

Schemi di posa mosaici / Mosaics laying patterns

Mosaico

34,5x34,5 cm - 13,58x13,58"

29 Price List (pz)

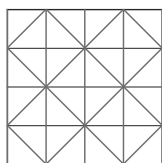

Uffizi MOP99

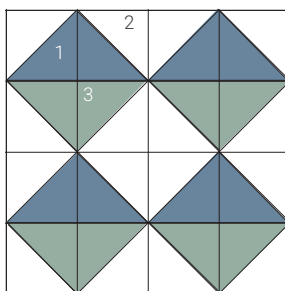
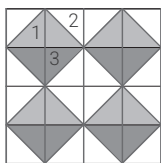
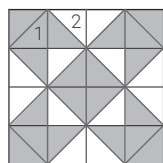

Indica nell'ordine i colori con cui vuoi creare il tuo mosaico scegliendoli dalla gamma colori.
Indicate in order the colours with which you want to create your mosaic, choosing them from the colours range.

Esempio di ordine
MOB4PU: col. 1 Cielo, col. 2 Sale
UFFIZI MOP99 col. 1 Cielo, col. 2 Sale, col. 3 Menta
UFFIZI MOP99 col. 1 Cielo, col. 2 Sale, col. 3 Menta

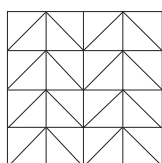

Ponte Vecchio MOP13

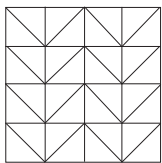
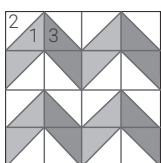
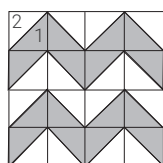

Boboli MOP74

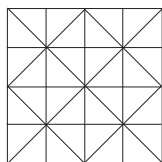
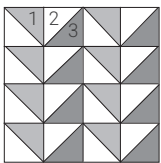
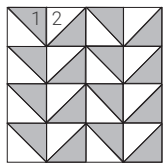

Signoria MOP16

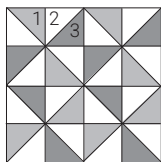
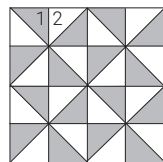

La posa senza fughe è fortemente sconsigliata in quanto si tratta di gres porcellanato tutta massa non rettificato. Addirittura non praticabile per ambienti esterni.
Consigliamo fughe di almeno 3 mm, così come prescritto dalle diverse norme di posa (in Italia UNI 11493).

Laying edge-to-edge without joints is strongly discouraged, indeed it is not practicable for external applications.

We recommend joints of at least 3 mm, according to the different laying standards (in Italy, UNI 11493).

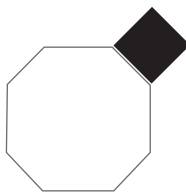

30x30
Ottagono

posa: 1 pezzo 30x30, 1 pezzo 12,2x12,2 tozzetto
pezzi a mq: 11,1 pz 30x30 ottagonale - 11,1 pz 12,2x12,2 tozzetto
installation: 1 pc 30x30 ottagonale, 1 pc 12,2x12,2 tozzetto
pieces x m2: 11,1 pcs 30x30 ottagonale - 11,1 pcs 12,2x12,2 tozzetto

Pitti



Sale - Cielo

Pavimento/Floor:

30x30 Pitti Ottagono A Sale Cielo - 12.2x12.2 Pitti Tozzetto Sale - 34.5x34.5 Pitti Mosaico Signoria Sale

Lista imballaggi per box / Packing list per box

Descrizione / Description		kg box	pz. box	mq box	box pallet	kg pallet
30x30	Formato Ottagono 30x30	20,20	15	1,127	20	404
30x30	Formato Ottagono A 30x30	20,20	15	1,127	20	404
30x30	Formato Ottagono B 30x30	20,20	15	1,127	20	404
12,2x12,2	Formato Tozzetto 12,2x12,2	0,26	34	0,507	-	-
12,2x12,2	Formato Tozzetto A 12,2x12,2	0,26	34	0,507	-	-
12,2x12,2	Formato Tozzetto B 12,2x12,2	0,26	34	0,507	-	-
Mosaico 4x4	Foglio sheet tessere 4x4	12	6	0,714	-	-

Old England

Old England, ispirata alle antiche cementine rinnovate in perfetto stile Ceramiche Grazia, è in gres porcellanato tutta massa con superficie già trattata R10, antiscivolo. Le piastrelle decorate richiamano le policromie degli impasti, molteplici le varianti di colore e di formato rendendo possibile la combinazione di molteplici varietà di posa. Questa serie è possibile utilizzarla a pavimento ma anche a rivestimento in ambienti sia interni che esterni, è particolarmente indicata nelle ristrutturazioni di edifici storici. Arricchita nella gamma da due nuovi colori di tendenza, Bristol e Oxford, da oggi si presta sempre di più anche ad ambienti contemporanei

Old England, inspired by the ancient "cementine" renovated in perfect Ceramiche Grazia style, is a full-body porcelain tile with an already treated R10 surface, non-slip. The decorated tiles recall the polychromy of the mixtures, multiple color variations and sizes make possible the combination of multiple varieties of laying. This collection can be used on the floor but also as wall tile in both indoor and outdoor environments and is particularly suitable for renovations of historic buildings. Enriched in the range by two new trendy colors, Bristol and Oxford, it is more and more suitable for contemporary interiors.



Designed by Maria Jachalska Interior Designer - Photographer: Nobert Banaszuk - Location: Libelta 27, Poznan

Dover - York - Chester

Pavimento/Floor:

20x20 Old England Dover - 6x20 Old England Listello Decoro Ed Chester - 20x20 Old England Ottagono Decoro Ed Chester
4x4 Old England Tozzetto Decoro Ed Chester - 20x20 Old England York - 6x20 Old England Listello Decoro Black Chester -
20x20 Old England Ottagono Decoro Black Chester - 4x4 Old England Tozzetto Decoro Black Chester



Designed by Gaia Mobili

Dover - Oxford

Pavimento/Floor:
20x20 Old England Ottagono Decoro Ed Oxford - 4x4 Old England Tozzetto Oxford



Designed by Maria Jachalska Interior Designer - Photographer: Nobert Banaszuk - Location: Libelta 27, Poznan

Dover - York - Chester

Pavimento/Floor:

20x20 Old England Dover - 6x20 Old England Listello Decoro Ed Chester - 20x20 Old England Ottagono Decoro Ed Chester
4x4 Old England Tozzetto Decoro Ed Chester - 20x20 Old England York - 6x20 Old England Listello Decoro Black Chester - 20x20
Old England Ottagono Decoro Black Chester - 4x4 Old England Tozzetto Decoro Black Chester





Designed by Architecture Laurent Boyer

Dover - York - Chester

Pavimento/Floor:
20x20 Old England Chester
20x20 Old England Ottagono Decoro Ed York
4x4 Old England Tozzetto Chester



Leeds - York

Pavimento/Floor:

20x20 Old England Leeds - 20x20 Old England York - 20x20 Old England Ottagono Decoro Black Leeds -
4x4 Old England Tozzetto Leeds - 6x20 Old England Listello Decoro Black Leeds



Designed by Architetto Luca Caprioli

Dover - York

Pavimento/Floor:
20x20 Old England Ottagono Decoro Ed York - 4x4 Old England Tozzetto Dover

Dover - Bath

Pavimento/Floor:
20x20 Old England Bath
20x20 Old England Ottagono Decoro Ed Bath
4x4 Old England Tozzetto Decoro Ed Bath
6x20 Old England Listello Decoro Ed Bath







London - Dover

Pavimento/Floor:
20x20 Old England Ottagono London - 20x20 Old England London - 4x4 Old England Tozzetto Decoro Ed London -
6x20 Old England Listello Decoro Ed London



Designed by Keramik Loft

Dover - Leeds

Pavimento/Floor:
20x20 Old England Leeds - 20x20 Old England Ottagono Decoro Ed Leeds - 4x4 Old England Tozzetto Decoro Ed Leeds
6x20 Old England Listello Decoro Ed Leeds

London - Dover

Pavimento/Floor:
20x20 Old England Ottagono London
20x20 Old England London
4x4 Old England Tozzetto Decoro Ed London
6x20 Old England Listello Decoro Ed London



Designed by Architetto Luca Caprioli







York - Dover

Pavimento/Floor:
20x20 Old England York
20x20 Old England Ottagono Decoro Black Dover
4x4 Old England Tozzetto Decoro Black Dover
6x20 Old England Listello Decoro Black Dover

Designed by Patrycja Suszek-Raczkowska / Poco Design
3d renders: Mateusz Jakubczyk/Visual CGI

Old England

Formato 20x20 / Size 20x20 7,87x7,87"

Spessore: ca. 8 mm / Thickness: ca. 0,3
Gres porcellanato tutta massa R10 / Full-body porcelain stoneware, R10
132 Price List (mq) Bristol - 92 Price List (mq) All Other Colors



20x20
Dover
OE1



20x20
Leeds
OE2



20x20
Chester
OE3

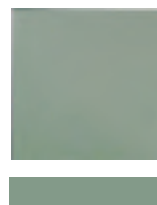

20x20
Bath
OE4



20x20
York
OE5

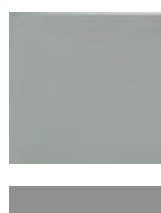

20x20
London
OE6



20x20
Oxford
OE7



20x20
Bristol
OE8

Formato Ottagono 20x20 / Size 20x20 7,87x7,87"

Spessore: ca. 8 mm / Thickness: ca. 0,3
Gres porcellanato tutta massa R10 / Full-body porcelain stoneware, R10
83 Price List (mq) Bristol - 129 Price List (mq) All Other Colors



Ottagono
Dover
OE01



Ottagono
Leeds
OE02



Ottagono
Chester
OE03



Ottagono
Bath
OE04

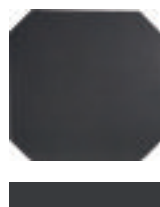

Ottagono
York
OE05



Ottagono
London
OE06

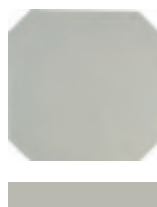

Ottagono
Oxford
OE07



Ottagono
Bristol
OE08

Formato Tozzetto 4x4 / Size Tozzetto 4x4 1,57x1,57"

Spessore: ca. 8 mm / Thickness: ca. 0,3
Gres porcellanato tutta massa R10 / Full-body porcelain stoneware, R10
38 Price List (pz) Bristol - 8 Price List (pz) All Other Colors

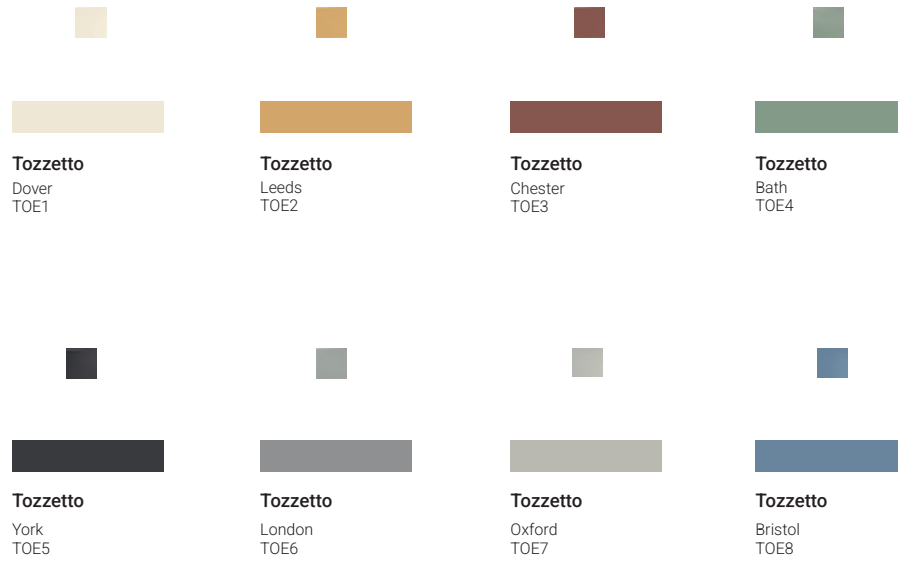

Old England

Decoro / Decoration

Ottagono Decoro ED

20x20 cm - 7,87x7,87"

134 Price List (mq)



Leeds
OEOD2



Chester
OEOD3



Bath
OEOD4



York
OEOD5



London
OEOD6



Oxford
OEOD7



Bristol
OEOD8

Ottagono Decoro Black*

20x20 cm - 7,87x7,87"

134 Price List (mq)



Dover
OEODB1



Leeds
OEODB2



Chester
OEODB3



Bath
OEODB4



London
OEODB6

* Le serigrafie su fondo York possono avere tonalità non identiche alle relative basi
Silk-screen printings on York background may have batches that are not identical to the relative bases

Pezzi speciali decorativi / Decorative special pieces

Listello Decoro ED

6x20 cm - 2,36x7,87"

56 Price List (pz)



Leeds
OELD2



Chester
OELD3



Bath
OELD4



York
OELD5



London
OELD6



Oxford
OELD7



Bristol
OELD8

Tozzetto Decoro ED

4x4 cm - 1,57x1,57"

38 Price List (pz)



Leeds
OEE2



Chester
OEE3



Bath
OEE4



York
OEE5



London
OEE6



Oxford
OEE7



Bristol
OEE8

Listello Decoro Black*

6x20 cm - 2,36x7,87"

56 Price List (pz)



Dover
OELDB1



Leeds
OELDB2



Chester
OELDB3



Bath
OELDB4



London
OELDB6

Tozzetto Decoro Black*

4x4 cm - 1,57x1,57"

38 Price List (pz)



Dover
OETDB1



Leeds
OETDB2



Chester
OETDB3



Bath
OETDB4



London
OETDB6

Old England

Pezzi speciali / *Special pieces*

15 Price List (Pz) Bristol - 105 Price List (Pz) All Other Colors

Zoccolo

10x20 cm - 3,94 x 7,87"

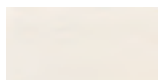

	Dover OEZ1
	Leeds OEZ2
	Chester OEZ3
	Bath OEZ4
	York OEZ5
	London OEZ6
	Oxford OEZ7
	Bristol OEZ8

La posa senza fuga è fortemente sconsigliata in quanto si tratta di gres porcellanato tutta massa non rettificato. Addirittura non praticabile per ambienti esterni. Consigliamo fughe di almeno 3 mm, così come prescritto dalle diverse norme di posa (in Italia UNI 11493).

Laying edge-to-edge without joints is strongly discouraged, indeed it is not practicable for external applications.

We recommend joints of at least 3 mm, according to the different laying standards (in Italy, UNI 11493).

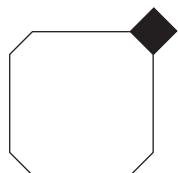

20x20
Ottagono

Posa: 1 pz 20x20 ottagono, 1 pezzo 4x4 tozzetto
 Pezzi a mq: 25 pz 20x20 ottagono - 25 pz 4x4 tozzetto
 Installation: 1 pc 20x20 ottagono, 1 pc 4x4 tozzetto
 Pieces x m2: 25 pcs 20x20 ottagono - 25 pcs 4x4 tozzetto

Lista imballaggi per box / Packing list per box

Descrizione / Description		kg box	pz.box	mq box	box pallet	kg pallet
20x20	Formato 20x20	21,60	30	1,20	54	1.166,40
20x20	Formato Ottagono 20x20	20,20	30	1,152	54	1.090,80
20x20	Ottagono Decoro ED	20,20	30	1,152	54	1.090,80
20x20	Ottagono Decoro Black	20,20	30	1,152	54	1.090,80
4x4	Formato Tozzetto 4x4	8,70	280	-	-	-
4x4	Tozzetto Decoro ED	8,70	280	-	-	-
4x4	Tozzetto Decoro Black	8,70	280	-	-	-
6x20	Listello Decoro ED	4,40	20	-	-	-
6x20	Listello Decoro Black	4,40	20	-	-	-
10x20	Zoccolo	6,60	20	-	-	-

Althaus

Althaus, evoluzione della collezione Old England. Grafiche studiate per ampliare la gamma prodotti della serie, considerato l'impatto e la riuscita del progetto iniziale. Gres porcellanato a tutta massa con superficie già trattata R10, antiscivolo, adatto a tutti gli ambienti. Particolarmente indicata nelle ristrutturazioni di edifici storici, grazie alle diverse decorazioni in stile Liberty, Classico e Retrò. Combinata a tinte di tendenza trasforma gli ambienti conferendo un tocco di suggestiva contemporaneità, anche grazie ai nuovi colori Bristol e Oxford.

Althaus, evolution of the Old England collection. Graphics designed to expand the product range of the series, considering the impact and success of the initial project. Full-body porcelain tile with already treated R10 surface, non-slip, suitable for all environments. Particularly suitable for renovations of historic buildings, thanks to different decorations in Liberty, Classic and Retro style. Combined with trendy shades, it transforms the environments giving a touch of evocative contemporaneity, also due to the new colors Bristol and Oxford.



Bristol - Dover

Pavimento/Floor:
20x20 Old England Dover - 20x20 Old England Bristol - 20x20 Althaus Lipsia Bristol





York - Dover - Leeds

Pavimento/Floor:
20x20 Old England York
20x20 Althaus Dresda York Leeds

Rivestimenti/Wall:
20x80 Electa Beige Matt
20x20 Electa Zoccolo Beige Matt
5.6x20 Electa Toro Beige Matt



Designed by architect Kamil Graczyk - Vame architekci

Dover - Chester

Pavimento/Floor:
20x20 Althaus Lipsia Chester



Dover - Bath - Sand

Pavimento/Floor:
20x20 Althaus Giralda Sand Bath

Rivestimenti/Wall:
20x20 Vintage Ivory Glossy - 20x20 Vintage Zoccolo Dark Dove Glossy - 3,5x20 Vintage Bordura Dark Dove Glossy



York - Bath - Dover

Pavimento/Floor:
20x20 Althaus Lipsia York Bath



Designed by Studio_Archede ed Eleonoramazzei_Photo

Dover - London

Pavimento/Floor:
20x20 Althaus Lipsia London

York - Dover - Bath

Pavimento/Floor:
20x20 Althaus Lipsia York Bath

Rivestimenti/Wall:
6,5x13 Essenze Nebbia Glossy
13x13 Essenze Zoccolo Nebbia Glossy



Designed by architect Kamil Graczyk - Vame architekci





London - Bristol - Dover

Pavimento/Floor:
20x20 Althaus Giralda Bristol London



Dover - London - York

Pavimento/Floor:
20x20 Althaus Giralda London York

Althaus

Formato 20x20 / Size 20x20 7,87x7,87"

Spessore: ca. 8 mm / Thickness: ca. 0,3
 Gres porcellanato tutta massa R10 / Full-body porcelain stoneware, R10
 132 Price List (mq) Bristol - 92 Price List (mq) All Other Colors

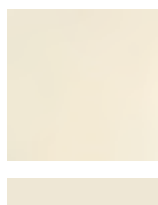

20x20
Dover
OE1



20x20
Leeds
OE2



20x20
Chester
OE3



20x20
Bath
OE4



20x20
York
OE5

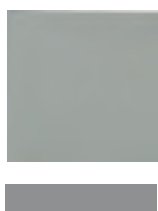

20x20
London
OE6

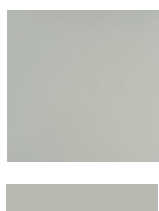

20x20
Oxford
OE7



20x20
Bristol
OE8

Decoro Berlino 20x20 / Decoration Berlino 20x20 7,87x7,87"

Spessore: ca. 8 mm / Thickness: ca. 0,3
 135 Price List (mq)

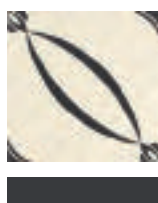

Berlino
York
AHB5

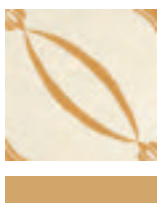

Berlino
Leeds
AHB2



Berlino
Chester
AHB3



Berlino
Bath
AHB4



Berlino
London
AHB6



Berlino
Oxford
AHB7

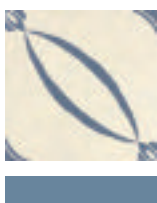

Berlino
Bristol
AHB8

Decoro Lipsia 20x20 / Decoration Lipsia 20x20 7,87x7,87"

Spessore: ca. 8 mm / Thickness: ca. 0,3
135 Price List (mq)

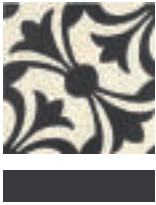

Lipsia
York
AHL5



Lipsia
Leeds
AHL2



Lipsia
Chester
AHL3



Lipsia
Bath
AHL4



Lipsia
London
AHL6



Lipsia
Oxford
AHL7



Lipsia
Bristol
AHL8

Decoro Lipsia 20x20 / Decoration Lipsia 20x20 7,87x7,87"

Spessore: ca. 8 mm / Thickness: ca. 0,3
135 Price List (mq)



Lipsia
London + York
AHL65



Lipsia
Leeds + Chester
AHL23



Lipsia
London + Chester
AHL63



Lipsia
York + Bath
AHL54



Lipsia
Oxford + Bristol
AHL78



Lipsia
Bristol + Leeds
AHL82

Althaus

Decoro Dresda 20x20 / Decoration Dresda 20x20 7,87x7,87"

Spessore: ca. 8 mm / Thickness: ca. 0,3
135 Price List (mq)



Dresda
London + York
AHD65



Dresda
York + Leeds
AHD52



Dresda
London + Chester
AHD63



Dresda
York + Bath
AHD45



Dresda
Bristol + Oxford
AHD87



Dresda
Leeds + Bristol
AHD28

Decoro Giralda 20x20 / Decoration Giralda 20x20 7,87x7,87"

Spessore: ca. 8 mm / Thickness: ca. 0,3
135 Price List (mq)

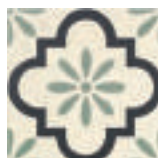

Giralda
York+Bath
GIRAP54

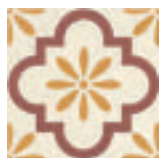

Giralda
Chester + Leeds
GIRAP98



Giralda
Sand + Bath
GIRAP24



Giralda
London + York
GIRAP65



Giralda
Bristol + London
GIRAP36

La posa senza fuga è fortemente sconsigliata in quanto si tratta di gres porcellanato tutta massa non rettificato. Addirittura non praticabile per ambienti esterni.
Consigliamo fughe di almeno 3 mm, così come prescritto dalle diverse norme di posa (in Italia UNI 11493).
Laying edge-to-edge without joints is strongly discouraged, indeed it is not practicable for external applications.
We recommend joints of at least 3 mm, according to the different laying standards (in Italy, UNI 11493).





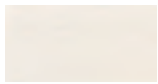

Pezzi speciali / Special pieces

15 Price List (Pz) Bristol - 105 Price List (Pz) All Other Colors

Zoccolo

10x20 cm - 3,94 x 7,87"



	Dover OEZ1
	Leeds OEZ2
	Chester OEZ3
	Bath OEZ4
	York OEZ5
	London OEZ6
	Oxford OEZ7
	Bristol OEZ8

Lista imballaggi per box / Packing list per box

Descrizione / Description		kg box	pz. box	mq box	box pallet	kg pallet
20x20	Formato 20x20	21,60	30	1,20	54	1.166,40
20x20	Decoro Berlino 20x20	21,60	30	1,20	54	1.166,40
20x20	Decoro Lipsia 20x20	21,60	30	1,20	54	1.166,40
20x20	Decoro Dresda 20x20	21,60	30	1,20	54	1.166,40
10x20	Zoccolo	6,60	20	-	-	-

Rivestimenti

Wall Tiles

Perfetta per rivestimenti di pareti interne, questa ceramica combina funzionalità e design, offrendo una soluzione elegante e durevole per trasformare ogni ambiente in un vero capolavoro di stile. Un mondo di tonalità e forme, mille sfaccettature che permettono di creare soluzioni progettuali adatte a ogni spazio, dal domestico al commerciale, dal più eclettico al più raffinato. Tutte le collezioni della serie condividono un'unica filigrana progettuale, un impasto ceramico uniforme che permette infinite possibilità di posa. I rivestimenti Grazia sono una tradizione per un arredo d'interni in evoluzione, ricco di dettagli, in grado di plasmare e vivificare gli ambienti.

Perfect for interior wall coverings, this ceramic tile combines functionality and design, offering an elegant and durable solution to transform any space into a true masterpiece of style. A world of colour shades and shapes, a thousand facets that allow to create design solutions suited to any space, from domestic to commercial, from the most eclectic to the most refined one. All collections of the series share a single design thread, a uniform ceramic body that allows infinite installation possibilities. Grazia wall coverings are a tradition for an evolving interior design, rich in details, capable of shaping and enlivening spaces.

Nexus

Nexus è la serie pensata per legare tra loro stili e cadenze cromatiche. Essenza della trasversalità di Grazia, permette di fungere da trait d'union tra i colori del nostro gres porcellanato tutta massa e i nuovi colori della serie Boiserie. Ma può essere usata anche da sola con pose creative, sempre in cadenza cromatica o a contrasto, con la nostra ampia varietà di pezzi speciali. Nexus è un legame tra il passato, il presente e il futuro della nostra visione della ceramica tradizionale.

Nexus is a series designed to join styles and chromatic tones. Symbol of Grazia's versatility, it serves as a trait d'union between the colours of our full-body porcelain stoneware floor tiles and the brand new colours of the BOISERIE series. It can also be laid alone in creative installations, in chromatic tones or in contrast, along with our widerange of special pieces. Nexus is a link between past, present, and future of our traditional ceramics vision.



Light Salvia matt

Rivestimenti/Wall

10x20 Nexus Light Salvia Matt

20x80 Boiserie Origins Boiserie Salvia Matt





Light Cotto Matt

Rivestimenti/Wall:

10x20 Nexus Light Cotto Matt

1,2x20 Nexus Coprispigolo Cotto Matt





Light Cemento Matt - Carbone Matt

Rivestimenti/Wall:
10x20 Nexus Light Cemento Matt
2x20 Nexus Tondo Carbone Matt
12x20 Nexus Finale Carbone Matt



Light Cielo matt

Rivestimenti/Wall:
10x20 Nexus Light Cielo matt - 2x20 Nexus Tondo Cielo matt

Pavimento/Floor:
20X20 Old England Bristol

Special Pieces



Tondo
2x20 cm



Coprispigolo
1,2x20 cm



Nexus Matt

Formato 10x20 / Size 10x20 3,93x7,87"

Spessore: ca. 10 mm / Thickness New Classic: ca. 0,4
91 Price List (mq)

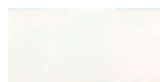

10x20
Bianco Matt
NE01

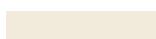
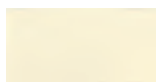

10x20
Light Beige Matt
NE06



10x20
Carbone Matt
NE11



10x20
Light Cielo Matt
NE12



10x20
Light Salvia Matt
NE13



10x20
Light Tortora Matt
NE14



10x20
Light Cemento Matt
NE15



10x20
Light Menta Matt
NE16



10x20
Light Senape Matt
NE17



10x20
Light Cotto Matt
NE18



10x20
Light Sabbia Matt
NE19

In questa collezione i colori dei fondi sono più chiari e sfumati rispetto ai pezzi speciali ad essi associati, tranne i colori bianco e carbone. L'effetto è volutamente nato per creare giochi cromatici come da tabella a pagina 23 "colore e materia" / In this collection, the background colors are lighter and more nuanced than the relevant special pieces, except for the colors white and charcoal. This effect was intentionally created in order to create chromatic interplay, as shown in the chart on page 23, "Color and Material."

* Pezzi smaltati su lato superiore / Pieces glazed on top

** Pezzo smaltato su uno dei due bordi laterali / Piece glazed on one of the two side edges.

Pezzi speciali / Special pieces

Toro*

6,5x20 cm - 2,56x7,87"
55 Price List (pz)



	Bianco Matt TO01
	Beige Matt TO06
	Carbone Matt TO111
	Cielo Matt TO112
	Salvia Matt TO113
	Tortora Matt TO114
	Cemento Matt TO115
	Menta Matt TO116
	Senape Matt TO117
	Cotto Matt TO118
	Sabbia Matt TO119

Angolo est. Toro*

6,5x3 cm - 2,56x1,18"
105 Price List (pz)



	Bianco Matt TOA01
	Beige Matt TOA06
	Carbone Matt TOA111
	Cielo Matt TOA112
	Salvia Matt TOA113
	Tortora Matt TOA114
	Cemento Matt TOA115
	Menta Matt TOA116
	Senape Matt TOA117
	Cotto Matt TOA118
	Sabbia Matt TOA119

Finale*

12x20 cm - 4,72x7,87"
58 Price List (pz)



	Bianco Matt FIN01
	Beige Matt FIN06
	Carbone Matt FIN111
	Cielo Matt FIN112
	Salvia Matt FIN113
	Tortora Matt FIN114
	Cemento Matt FIN115
	Menta Matt FIN116
	Senape Matt FIN117
	Cotto Matt FIN118
	Sabbia Matt FIN119

Angolo Finale*

3x12 cm - 1,18x4,72"
72 Price List (pz)



	Bianco Matt FINA01
	Beige Matt FINA06
	Carbone Matt FINA111
	Cielo Matt FINA112
	Salvia Matt FINA113
	Tortora Matt FINA114
	Cemento Matt FINA115
	Menta Matt FINA116
	Senape Matt FINA117
	Cotto Matt FINA118
	Sabbia Matt FINA119

Tondo**

2x20 cm - 0,79x7,87"
57 Price List (pz)



	Bianco Matt TAM1
	Beige Matt TAM10
	Carbone Matt TAM111
	Cielo Matt TAM112
	Salvia Matt TAM113
	Tortora Matt TAM114
	Cemento Matt TAM115
	Menta Matt TAM116
	Senape Matt TAM117
	Cotto Matt TAM118
	Sabbia Matt TAM119

Zoccolo

20x20 cm - 7,87x7,87"
22 Price List (pz)



	Bianco Matt ZOA01
	Beige Matt ZOA06
	Carbone Matt ZOA111
	Cielo Matt ZOA112
	Salvia Matt ZOA113
	Tortora Matt ZOA114
	Cemento Matt ZOA115
	Menta Matt ZOA116
	Senape Matt ZOA117
	Cotto Matt ZOA118
	Sabbia Matt ZOA119

Angolo Zoccolo

2,2x20 cm - 0,87x7,87"
72 Price List (pz)



	Bianco Matt ZOA01
	Beige Matt ZOA06
	Carbone Matt ZOA111
	Cielo Matt ZOA112
	Salvia Matt ZOA113
	Tortora Matt ZOA114
	Cemento Matt ZOA115
	Menta Matt ZOA116
	Senape Matt ZOA117
	Cotto Matt ZOA118
	Sabbia Matt ZOA119

Coprispigolo

1,2x20 cm - 0,47x7,87"
19 Price List (pz)



	Bianco Matt COP01
	Beige Matt COP06
	Carbone Matt COP111
	Cielo Matt COP112
	Salvia Matt COP113
	Tortora Matt COP114
	Cemento Matt COP115
	Menta Matt COP116
	Senape Matt COP117
	Cotto Matt COP118
	Sabbia Matt COP119

Nexus



Light Cotto Matt

Rivestimenti/Wall:
10x20 Nexus Light Cotto Matt
1,2x20 Nexus Coprispigolo Cotto Matt

Lista imballaggi per box / Packing list per box

Matt

Descrizione / Description		kg box	pz. box	mq box	box pallet	kg. pallet
10x20	Formato 10x20	18,20	50	1,00	60	1.092
2x20	Tondo	5	52	-	-	-
6,5x20	Toro	10	32	-	-	-
6,5x3	Ang. est toro	1,35	40	-	-	-
12x20	Finale	4,85	10	-	-	-
1,2x20	Angolo est. finale	1,70	70	-	-	-
20x20	Zoccolo	12,4	16	-	-	-
2x20	Ang. est par. zoccolo	1,95	30	-	-	-
1,2x20	Coprispigolo	0,75	21	-	-	-

Essenze

Essenze, una varietà di colori. Bicottura in pasta bianca da rivestimento con superficie lucida e craquelé. Serie formata da diverse alternative di colori, decorazioni e formati. Estremamente versatile per ogni tipo di realizzazione: anglosassone, tradizionale, classica, liberty, contemporanea e shabby-chic. Adatta per restauri conservativi, ristrutturazioni, edifici storici e ambienti pubblici, in particolare in quelli dedicati alla ristorazione dal gusto vintage e retrò. Uno dei nostri prodotti più distintivi, data la molteplicità di colori e finiture, da oggi ulteriormente arricchiti dai nuovi colori Ceruleo, Ocean, Germoglio, Nebbia, e dai nuovi pezzi speciali finale e zoccolo 13x13.

Essenze, a multitude of colours. Double fired white body wall tile in a glossy and craquele finish. This range has endless configurations of colours, decors and sizes. Extremely versatile in all settings; Victorian, traditional, classic, Art Nouveau, contemporary or shabby-chic. Great for conservative restorations and the renovation of historical buildings and public spaces, especially the catering dedicated ones, with a vintage and retro touch. One of our most distinctive products, thanks to the variety of colours and trims, now further enriched by the new colours Ceruleo, Ocean, Germoglio, Nebbia, and the new special pieces "finale" and plinth 13x13.



Designed by Ida Agemo & Gitte Nøhr Aquadomo ApS

Magnolia Glossy

Rivestimenti/Wall:
6,5x13 Essenze Magnolia Glossy

Magnolia Glossy

Rivestimenti/Wall:
6.5X13 Essenze Magnolia Glossy
1.2x26 Coprispigolo Essenze Magnolia Glossy



Designed by Ida Agemo & Gitte Nøhr Aquadomo ApS





Magnolia Glossy

Rivestimenti/Wall:

7,5x13 Essenze Capitello Magnolia Glossy - 7,5x3 Essenze Ang. Est Capitello Magnolia Glossy - 6,5x13 Essenze Magnolia Glossy - 13x13 Essenze Magnolia Glossy - 1,2x26 Essenze Coprispigolo Magnolia Glossy



Designed by @Vonholmback & Gitte Nahr Aquadomo ApS

Magnolia Glossy

Rivestimenti/Wall:
5x13 Essenze Bordura Magnolia Glossy - 6,5x13 Essenze Magnolia Glossy - 1,2x26 Essenze Coprispigolo Pino Glossy

Ice Glossy

Rivestimenti/Wall:

6,5x13 Essenze Ice Glossy

5x13 Essenze Bordura Ice Glossy

5x3 Essenze Ang. Est Bordura Ice Glossy

1,2x26 Essenze Coprispigo Ice Glossy

13x13 Essenze Zoccolo Ice Glossy

Pavimento/Floor:

30x30 Brera Ottagono Sale

4x4 Brera Tozzetto Carbone



Designed by Stephanie A. Copenhagen & Gitte Nøhr Aquadomo ApS





Genziana Glossy - Ice Glossy

Rivestimenti/Wall:
6,5x13 Essenze Genziana Glossy - 13x13 Essenze Ice Glossy



Designed by Stephanie A. Copenhagen & Gitte Nahr Aquadomo ApS

Ice Glossy

Rivestimenti/Wall:
6,5x13 Essenze Ice Glossy - 5x13 Essenze Bordura Ice Glossy - 5x3 Ang. Essenze Est Bordura Ice Glossy - 1,2x26 Essenze Coprispigo Ice Glossy



Pino Glossy

Rivestimenti/Wall:
6,5X13 Essenze Pino Glossy

Pavimento/Floor:
20x20 Old England Bath - 20x20 Old England Ottagono Decoro Ed Bath - 4x4 Old England Tozzetto Bath



Designed by @Vonholmback & Gitte Nahr Aquadomo ApS

Pino Glossy

Rivestimenti/Wall:
6,5x13 Essenze Pino Glossy - 1,2x26 Essenze Coprispigo Pino Glossy

Pavimento/Floor:
30x30 Brera Ottagono Sale - 4x4 Brera Tozzetto Carbone



Felce Craquelé

Rivestimenti/Wall:

13x13 Essenze Felce Craquelé - 7,5x13 Essenze Capitello Felce Craquelé - 13x13 Essenze Neoclassico Felce Craquelé
2,5x26 Essenze Listello P. Felce Craquelé



Genziana Glossy

Rivestimenti/Wall:

13x13 Essenze Genziana Glossy - 7,5x13 Essenze Capitello Genziana Glossy - 13x13 Essenze Voluta Genziana Glossy



Oceano Glossy

Rivestimenti/Wall:
6,5x13 Essenze Oceano Glossy



Germoglio Glossy

Rivestimenti/Wall:
6,5x13 Essenze Germoglio Glossy



Designed by Stephanie A. Copenhagen & Gitte Nahr Aquadomo ApS

Ice Glossy

Rivestimenti/Wall:

6,5x13 Essenze Ice Glossy - 5x13 Essenze Bordura Ice Glossy - 5x3 Ang. Essenze Est Bordura Ice Glossy - 1,2x26 Essenze Coprispigolo Ice Glossy - 13x13 Essenze Zoccolo Ice

Pavimento/Floor:

30x30 Brera Ottagono Sale - 4x4 Brera Tozzetto Carbone

Special Pieces

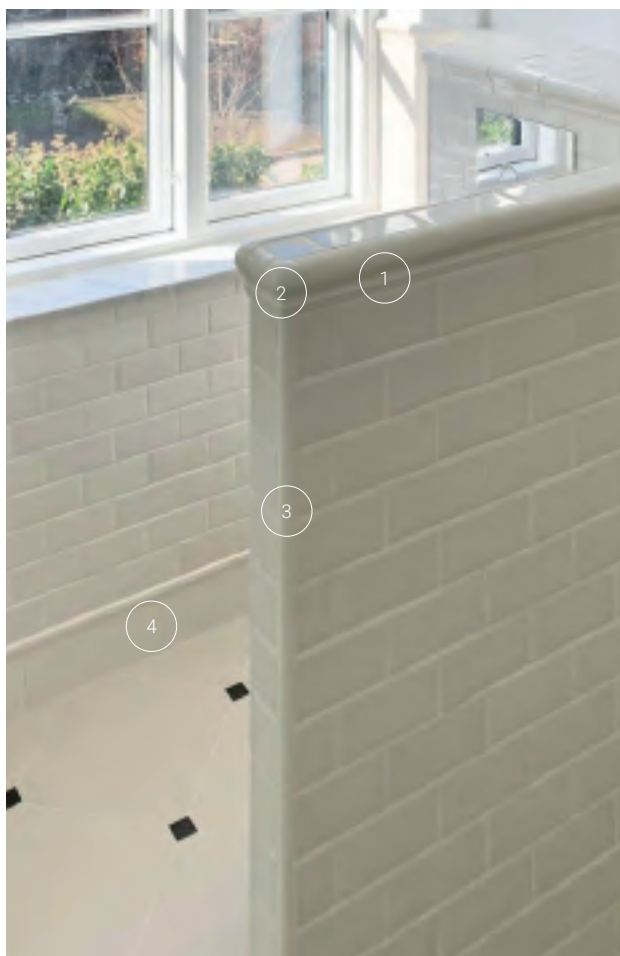
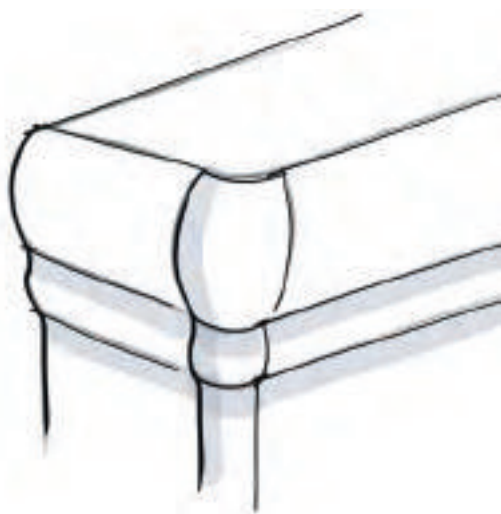

Essenze Glossy

Formato 13x13 / Size 13x13 5,12x5,12"

Spessore: ca. 10 mm / Thickness: ca. "0,4
127 Price List (mq)

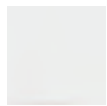

13x13
Ice Glossy
AV01



13x13
Magnolia Glossy
ES01



13x13
Primula Glossy
ES02



13x13
Gelsomino Glossy
ES03



13x13
Felce Glossy
ES04



13x13
Pino Glossy
ES05



13x13
Genziana Glossy
ES06



13x13
Ceruleo Glossy
ES03



13x13
Oceano Glossy
ES015



13x13
Germoglio Glossy
ES017



13x13
Nebbia Glossy
ES018

Formato 6,5x13 / Size 6,5x13 2,56x5,12"

Spessore: ca. 10 mm / Thickness: ca. "0,4
85 Price List (mq)



6,5x13
Ice Glossy
NN90



6,5x13
Magnolia Glossy
NN10



6,5x13
Primula Glossy
NN20



6,5x13
Gelsomino Glossy
NN30



6,5x13
Felce Glossy
NN40



6,5x13
Pino Glossy
NN50



6,5x13
Genziana Glossy
NN60



6,5x13
Ceruleo Glossy
NN130



6,5x13
Oceano Glossy
NN150



6,5x13
Germoglio Glossy
NN170



6,5x13
Nebbia Glossy
NN180

Pezzi speciali / Special pieces

Bordura Lineare*
5x13 cm - 1,97x5,12"
55 Price List (pz)



	Ice Glossy BAV01
	Magnolia Glossy BOR01
	Primula Glossy BOR02
	Gelsomino Glossy BOR03
	Felce Glossy BOR04
	Pino Glossy BOR05
	Genziana Glossy BOR06
	Ceruleo Glossy BOR013
	Oceano Glossy BOR015
	Germoglio Glossy BOR017
	Nebbia Glossy BOR018

Ang. Est. Par.*
5x3 cm - 1,97x1,18"
105 Price List (pz)



	Ice Glossy BAV011
	Magnolia Glossy BOA01
	Primula Glossy BOA02
	Gelsomino Glossy BOA03
	Felce Glossy BOA04
	Pino Glossy BOA05
	Genziana Glossy BOA06
	Ceruleo Glossy BOA013
	Oceano Glossy BOA015
	Germoglio Glossy BOA017
	Nebbia Glossy BOA018

Capitello*
7,5x13 cm - 2,95x5,12"
45 Price List (pz)



	Ice Glossy CAP09
	Magnolia Glossy CAP01
	Primula Glossy CAP02
	Gelsomino Glossy CAP03
	Felce Glossy CAP04
	Pino Glossy CAP05
	Genziana Glossy CAP06
	Ceruleo Glossy CAP013
	Oceano Glossy CAP015
	Germoglio Glossy CAP017
	Nebbia Glossy CAP018

Ang. Est. Capitello*
7,5x3 cm - 2,95x1,18"
105 Price List (pz)



	Ice Glossy CAAP09
	Magnolia Glossy CAAP01
	Primula Glossy CAAP02
	Gelsomino Glossy CAAP03
	Felce Glossy CAAP04
	Pino Glossy CAAP05
	Genziana Glossy CAAP06
	Ceruleo Glossy CAAP013
	Oceano Glossy CAAP015
	Germoglio Glossy CAAP017
	Nebbia Glossy CAAP018

Listello P.
2,5x26 cm - 0,98x10,24"
34 Price List (pz)



	Ice Glossy LIP01
	Magnolia Glossy LISTP01
	Primula Glossy LISTP02
	Gelsomino Glossy LISTP03
	Felce Glossy LISTP04
	Pino Glossy LISTP05
	Genziana Glossy LISTP06

Matita Capitello
2x26 cm - 0,79x10,24"
34 Price List (pz)



	Ice Glossy MATC09
	Magnolia Glossy MATC01
	Primula Glossy MATC02
	Gelsomino Glossy MATC03
	Felce Glossy MATC04
	Pino Glossy MATC05
	Genziana Glossy MATC06
	Ceruleo Glossy MATC013
	Oceano Glossy MATC015
	Germoglio Glossy MATC017
	Nebbia Glossy MATC018

Zoccolo
13x13 cm - 5,12x5,12"
72 Price List (pz)



	Ice Glossy ZE09
	Magnolia Glossy ZE01
	Primula Glossy ZE02
	Gelsomino Glossy ZE03
	Felce Glossy ZE04
	Pino Glossy ZE05
	Genziana Glossy ZE06
	Ceruleo Glossy ZE013
	Oceano Glossy ZE015
	Germoglio Glossy ZE017
	Nebbia Glossy ZE018

Angolo Zoccolo
1,7x13 cm - 0,67x5,12"
74 Price List (pz)



	Ice Glossy ZAE09
	Magnolia Glossy ZAE01
	Primula Glossy ZAE02
	Gelsomino Glossy ZAE03
	Felce Glossy ZAE04
	Pino Glossy ZAE05
	Genziana Glossy ZAE06
	Ceruleo Glossy ZAE013
	Oceano Glossy ZAE015
	Germoglio Glossy ZAE017
	Nebbia Glossy ZAE018

Coprispigolo
1,2x26 cm - 0,47x10,24"
34 Price List (pz)



	Ice Glossy COP90
	Magnolia Glossy COP10
	Primula Glossy COP20
	Gelsomino Glossy COP30
	Felce Glossy COP40
	Pino Glossy COP50
	Genziana Glossy COP60
	Ceruleo Glossy COP130
	Oceano Glossy COP150
	Germoglio Glossy COP170
	Nebbia Glossy COP180

* **Pezzi smaltati su lato superiore / Pieces glazed on top**

Lo smalto sulla parte superiore del Capitello della serie **Essenze** a causa della lavorazione del prodotto è più chiaro rispetto allo smalto della parte frontale
The glaze on the top of the Capitello **Essenze** is lighter than the glaze on the front of the piece due to the production process of the product

Essenze Glossy

Pezzi speciali decorativi/ *Decorative special pieces*

Liberty

13x13 cm - 5,12X5,12"

16 Price List (pz)

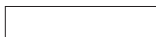

Ice Glossy
LIB09



Magnolia Glossy
LIB01



Primula Glossy
LIB02



Gelsomino Glossy
LIB03



Felce Glossy
LIB04



Pino Glossy
LIB05



Genziana Glossy
LIB06

Voluta

13x13 cm - 5,12X5,12"

16 Price List (pz)



Ice Glossy
V009



Magnolia Glossy
V001



Primula Glossy
V002



Gelsomino Glossy
V003



Felce Glossy
V004



Pino Glossy
V005



Genziana Glossy
V006

Neoclassico

13x13 cm - 5,12X5,12"

16 Price List (pz)



Ice Glossy
NE009



Magnolia Glossy
NE001



Primula Glossy
NE002



Gelsomino Glossy
NE003



Felce Glossy
NE004



Pino Glossy
NE005



Genziana Glossy
NE006

Liberty

6,5x13 cm - 2,56x5,12"
30 Price List (pz)

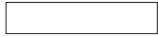

Ice Glossy
LIB900



Magnolia Glossy
LIB100



Primula Glossy
LIB200



Gelsomino Glossy
LIB300



Felce Glossy
LIB400



Pino Glossy
LIB500



Genziana
LIB600

Voluta

6x26 cm - 2,36x10,24"
24 Price List (pz)



Ice Glossy
VO900



Magnolia Glossy
VO100



Primula Glossy
VO200



Gelsomino Glossy
VO300



Felce Glossy
VO400

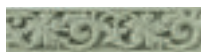

Pino Glossy
VO500



Genziana
VO600

Neoclassico

6x26 cm - 2,36x10,24"
24 Price List (pz)



Ice Glossy
NEO900

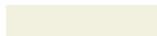

Magnolia Glossy
NEO100

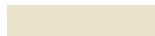

Primula Glossy
NEO200



Gelsomino Glossy
NEO300



Felce Glossy
NEO400



Pino Glossy
NEO500



Genziana
NEO600

Essenze Glossy

Mosaici / Mosaics

Mosaico tessere 3x3 / Sheet mosaic tiles 3x3

30X30 cm - 11,81x11,81"

28 Price List (Pz)



Ice Glossy
MOSE9

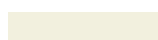
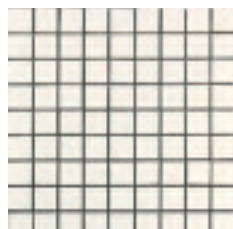

Magnolia Glossy
MOSE1

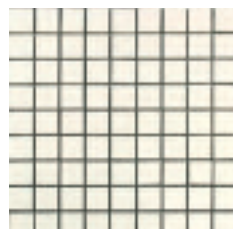

Primula Glossy
MOSE2

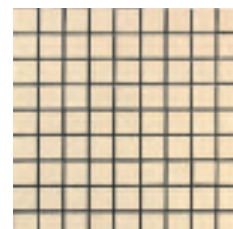

Gelsomino Glossy
MOSE3

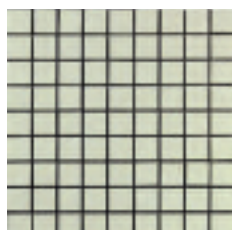

Felce Glossy
MOSE4

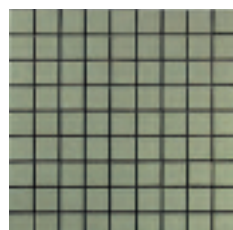

Pino Glossy
MOSE5

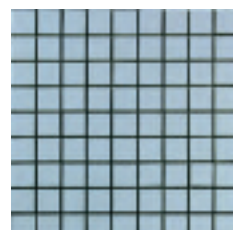

Genziana Glossy
MOSE6

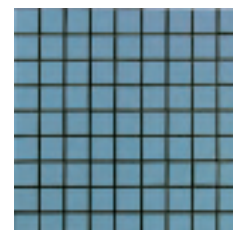

Ceruleo Glossy
MOSE13

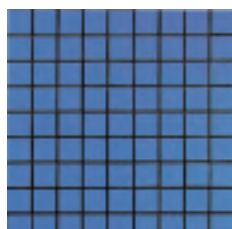

Oceano Glossy
MOSE15

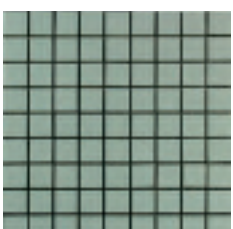

Germoglio Glossy
MOSE17



Nebbia Glossy
MOSE18

Mosaico tessere 3x6 / Sheet mosaic tiles 3x6

30X30 cm - 11,81x11,81"

28 Price List (Pz)



Ice Glossy
MOSAIC9



Magnolia Glossy
MOSAIC1



Primula Glossy
MOSAIC2

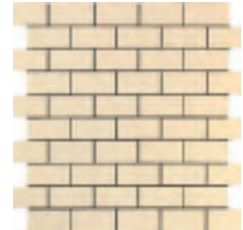

Gelsomino Glossy
MOSAIC3



Felce Glossy
MOSAIC4



Pino Glossy
MOSAIC5

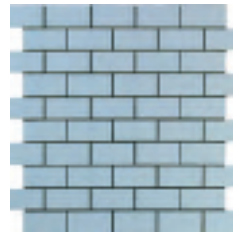

Genziana Glossy
MOSAIC6

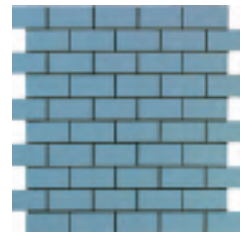

Ceruleo Glossy
MOSAIC13

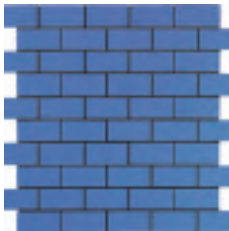

Oceano Glossy
MOSAIC15



Germoglio Glossy
MOSAIC17

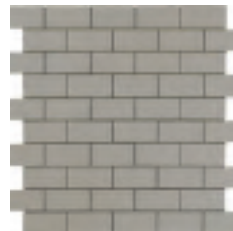

Nebbia Glossy
MOSAIC18

Essenze Craquelè

Formato 13x13 / Size 13x13 5,12x5,12"

Spessore: ca. 10 mm / Thickness: ca. "0,4
127 Price List (mq)



13x13
Bianco Craquelè
ES010



13x13
Magnolia Craquelè
ES07



13x13
Felce Craquelè
ES08



13x13
Greige Craquelè
ES012



13x13
Argento Craquelè
ES011



13x13
Ceruleo Craquelè
ES014



13x13
Oceano Craquelè
ES016

Formato 6,5x13 / Size 6,5x13 2,56x5,12"

Spessore: ca. 10 mm / Thickness: ca. "0,4
85 Price List (mq)

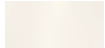

6,5x13
Bianco Craquelè
NN100



6,5x13
Magnolia Craquelè
NN70



6,5x13
Felce Craquelè
NN80



6,5x13
Greige Craquelè
NN120



6,5x13
Argento Craquelè
NN110



6,5x13
Ceruleo Craquelè
NN140









6,5x13
Oceano Craquelè
NN160

Pezzi speciali / *Special pieces*

Bordura Lineare*

5x13 cm - 1,97x5,12"
55 Price List (pz)









	Bianco Craquelè BOR010
	Magnolia Craquelè BOR07
	Felce Craquelè BOR08
	Greige Craquelè BOR012
	Argento Craquelè BOR011
	Ceruleo Craquelè BOR014
	Oceano Craquelè BOR016

Ang. Est. Par.*

5x3 cm - 1,97x1,18"
105 Price List (pz)









	Bianco Craquelè BOA010
	Magnolia Craquelè BOA07
	Felce Craquelè BOA08
	Greige Craquelè BOA012
	Argento Craquelè BOA011
	Ceruleo Craquelè BOA014
	Oceano Craquelè BOA016

Capitello*

7,5x13 cm - 2,95x5,12"
45 Price List (pz)









	Bianco Craquelè CAP10
	Magnolia Craquelè CAP07
	Felce Craquelè CAP08
	Greige Craquelè CAP012
	Argento Craquelè CAP011
	Ceruleo Craquelè CAP014
	Oceano Craquelè CAP016

Ang. Est.Par. Capitello*

7,5x3 cm - 2,95x1,18"
105 Price List (pz)









	Bianco Craquelè CAAP10
	Magnolia Craquelè CAAP07
	Felce Craquelè CAAP08
	Greige Craquelè CAAP012
	Argento Craquelè CAAP011
	Ceruleo Craquelè CAAP014
	Oceano Craquelè CAAP016

Matita Capitello

2x26 cm - 0,79x10,24"
34 Price List (pz)









	Bianco Craquelè MATC010
	Magnolia Craquelè MATC07
	Felce Craquelè MATC08
	Argento Craquelè MATC011
	Greige Craquelè MATC012
	Ceruleo Craquelè MATC014
	Oceano Craquelè MATC016

Zoccolo

13x13 cm - 5,12x5,12"
72 Price List (pz)









	Bianco Craquelè ZE010
	Magnolia Craquelè ZE07
	Felce Craquelè ZE08
	Argento Craquelè ZE011
	Greige Craquelè ZE012
	Ceruleo Craquelè ZE014
	Oceano Craquelè ZE016

Angolo Zoccolo

1,7x13 cm - 0,67x5,12"
74 Price List (pz)









	Bianco Craquelè ZAE010
	Magnolia Craquelè ZAE07
	Felce Craquelè ZAE08
	Argento Craquelè ZAE011
	Greige Craquelè ZAE012
	Ceruleo Craquelè ZAE014
	Oceano Craquelè ZAE016

Coprispigolo

1,2x26 cm - 0,47x10,24"
34 Price List (pz)





	Bianco Craquelè COP100
	Magnolia Craquelè COP70
	Felce Craquelè COP80
	Argento Craquelè COP110
	Greige Craquelè COP120
	Ceruleo Craquelè COP140
	Oceano Craquelè COP160

Listello P.

2,5x26 cm - 0,98x10,24"
34 Price List (pz)

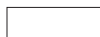

	Bianco Craquelè LISTP010
	Magnolia Craquelè LISTP07
	Felce Craquelè LISTP08

Si consiglia di trattare gli smalti craquelé con impregnante prima della stuccatura. Lo smalto sulla parte superiore del Capitello della serie Essenze è a causa della lavorazione del prodotto più chiaro rispetto allo smalto della parte frontale
We suggest to treat the crackle glazes with appropriate sealer before grouting. The glaze on the top of the Capitello Essenze is lighter than the glaze on the front of the piece due to the production process of the product

* Pezzi smaltati su lato superiore / *Pieces glazed on top*

Essenze Craquelé

Pezzi speciali decorativi/ *Decorative special pieces*

Liberty

13x13 cm - 5,12X5,12"

16 Price List (pz)

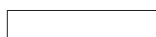

Bianco Craquelé
LIB010



Magnolia Craquelé
LIB07



Felce Craquelé
LIB08

Voluta

13x13 cm - 5,12X5,12"

16 Price List (pz)



Bianco Craquelé
V0010

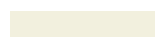

Magnolia Craquelé
V007



Felce Craquelé
V008

Neoclassico

13x13 cm - 5,12X5,12"

16 Price List (pz)

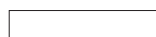

Bianco Craquelé
NEO010



Magnolia Craquelé
NEO07



Felce Craquelé
NEO08

Liberty

6,5x13 cm - 2,36x5,12"

30 Price List (pz)



Bianco Craquelé
LIB1000



Magnolia Craquelé
LIB700



Felce Craquelé
LIB800

Voluta

6x26 cm - 2,36x10,24"

24 Price List (pz)

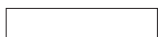

Bianco Craquelé
VO1000



Magnolia Craquelé
VO700



Felce Craquelé
VO800

Neoclassico

6x26 cm - 2,36x10,24"

24 Price List (pz)



Bianco Craquelé
NEO1000



Magnolia Craquelé
NEO700



Felce Craquelé
NEO800

Si consiglia di trattare gli smalti craquelé con impregnante prima della stuccatura. Lo smalto sulla parte superiore del Capitello della serie Essenze è a causa della lavorazione del prodotto più chiaro rispetto allo smalto della parte frontale
We suggest to treat the crackle glazes with appropriate sealer before grouting. The glaze on the top of the Capitello Essenze is lighter than the glaze on the front of the piece due to the production process of the product

Essenze



Pino Glossy

Rivestimenti/Wall:
6,5x13 Essenze Pino Glossy

Pavimento/Floor:
20x20 Old England Bath - 20x20 Old England Ottagono Decoro Ed Bath - 4x4 Old England Tozzetto Bath

Lista imballaggi per box / Packing list per box

Descrizione / Description		kg box	pz. box	mq box	box pallet	kg. pallet
13x13	Formato 13x13	8,5	30	0,507	114	969
6,5x13	Formato 6,5x13	8,5	60	0,507	114	969
Mosaico 30x30	Mosaico tessere 3x3	7,45	6	0,540	-	-
Mosaico 30x30	Mosaico tessere 3x6	7,90	6	0,540	-	-
5x13	Bordura Lineare	6	42	-	-	-
5x3	Angolo est. par. bordura	1,70	60	-	-	-
7,5x13	Capitello	7,90	28	-	-	-
7,5x3	Ang. est par. capitello	1,39	14	-	-	-
2,5x26	Listello P.	2,59	27	-	-	-
2x26	Matita capitello	4,5	36	-	-	-
13x13	Voluta Liberty	6,2	20	-	-	-
6x26	Voluta Neoclassico	6,8	30	-	-	-
13x13	Neoclassico	6,8	30	-	-	-
13x13	Liberty	5,2	20	-	-	-
6,5x13	Liberty	5,2	40	-	-	-
1,2x26	Coprispigolo	0,85	21	-	-	-
13x13	Zoccolo	5,28	22	-	-	-
1,7x13	Angolo Zoccolo	1	28	-	-	-

Melange

Melange, sfumature e armonie di colori. Bicottura tradizionale in pasta bianca da rivestimento con superficie lucida e fortemente stonalizzata nel formato 6,5x13 e leggermente nel 13x13. Nella sua estrema semplicità questa serie si adatta ad ambienti classici, metropolitani e retrò.

Melange, nuances and harmonies of colours. Double fired white body glossy wall tile, heavily shaded in the 6.5x13 and lightly shaded in the 13x13 size. This simple range will easily fit into any classic, modern or retrò setting.



Light Blue Glossy

Rivestimenti/Wall:

13x13 Melange Light Blue Glossy - 2x26 Melange Matita Capitello Light Blue Glossy - 6,5x13 Melange Light Blue Glossy



Milk Glossy

Rivestimenti/Wall:

13x13 Melange Milk Glossy - 2x26 Melange Matita Capitello Milk Glossy - 6,5x13 Melange Milk Glossy



Multicolor (Butter & Green Tea) Glossy

Rivestimenti/Wall:
6,5x13 Melange Multicolor Glossy

Green Tea Glossy

Rivestimenti/Wall:
6,5x13 Melange Green Tea Glossy







Grey Glossy

Rivestimenti/Wall:
5,5x26 Melange Toro Grey Glossy - 13x13 Melange Grey Glossy - 2x26 Melange Matita Capitello Grey Glossy
6,5x13 Melange Grey Glossy

Special Pieces



Toro
5,5x26 cm



Matita Capitello
2x26 cm



Melange Glossy

Formato 13x13 / Size 13x13 5,12x5,12"

Spessore: ca. 10 mm / Thickness: ca. "0,4
95 Price List (mq)

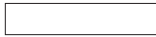

13x13
Milk Glossy
MEL1



13x13
Butter Glossy
MEL2



13x13
Light Blue Glossy
MEL3



13x13
Green Tea Glossy
MEL4



13x13
Grey Glossy
MEL5

Formato 6,5x13 / Size 6,5x13 2,56x5,12"

Spessore: ca. 10 mm / Thickness: ca. "0,4
85 Price List (mq)



6,5x13
Milk Glossy
MM1



6,5x13
Butter Glossy
MM2



6,5x13
Light Blue Glossy
MM3



6,5x13
Green Tea Glossy
MM4



6,5x13
Grey Glossy
MM5



VShade Milk Glossy
MM1



VShade Butter Glossy
MM2



VShade Light Blue Glossy
MM3



VShade Green Tea Glossy
MM4



VShade Grey Glossy
MM5



VShade Multicolor
MM6

Pezzi speciali / Special pieces

Toro*

5,5x26 cm - 2,16x10,24"
71 Price List (pz)



	Milk Glossy TOM1
	Butter Glossy TOM2
	Light Blue Glossy TOM3
	Green Tea Glossy TOM4
	Grey Glossy TOM5

Ang. Est. Toro*

5,5x2 cm - 2,16x0,79"
105 Price List (pz)



	Milk Glossy TOMA1
	Butter Glossy TOMA2
	Light Blue Glossy TOMA3
	Green Tea Glossy TOMA4
	Grey Glossy TOMA5

Matita Capitello

2x26 cm - 0,79x10,24"
57 Price List (pz)



	Milk Glossy MAT1
	Butter Glossy MAT2
	Light Blue Glossy MAT3
	Green Tea Glossy MAT4
	Grey Glossy MAT5

Coprispigolo

1,2x26 cm - 0,47x10,24"
56 Price List (pz)



	Milk Glossy COM1
	Butter Glossy COM2
	Light Blue Glossy COM3
	Green Tea Glossy COM4
	Grey Glossy COM5

Lista imballaggi per box / Packing list for box

Descrizione / Description	kg box	pz.box	mq box	box pallet	kg. pallet
13x13 Formato 13x13	8,5	30	0,507	114	969
6,5x13 Formato 6,5x13	8,5	60	0,507	114	969
5,5x26 Toro	5	20	-	-	-
5,5x2 Angolo est. Toro	1,36	40	-	-	-
2x26 Matita Capitello	4,5	36	-	-	-
1,2x26 Coprispigolo	0,85	21	-	-	-

* Pezzi smaltati su lato superiore / Pieces glazed on top

Vintage

Vintage, serie dalle superfici brillanti realizzata in tinte forti, bicottura tradizionale da rivestimento, elevata consistenza degli smalti e delle materie prime. Può essere utilizzata nella sua forma essenziale con l'ottagono e il tozzetto a contrasto oppure completata con il 10x20 nello stesso colore del tozzetto. Corredata di numerosi pezzi di finitura, è particolarmente in sintonia con ambienti di sapore vintage, ma combinata a materiali di tendenza trasforma un ambiente in contemporaneo e di grande effetto. Per completare ulteriormente la gamma colori e pezzi speciali, sono stati introdotti un nuovo colore con finitura lucida e due nuovi colori con smalto effetto craquelé. Il tutto corredato da relativi pezzi speciali.

Vintage, collection with bright surfaces made in strong colors, traditional double fired wall tile, high consistency of glazes and raw materials. It can be used in its essential form with the octagon and the contrasting taco or complete with the 10x20 tile in the same color of the tozzetto. Equipped with numerous finishing pieces, it is particularly in tune with environments of vintage flavor, but when combined with trendy materials, it transforms them into contemporary and impressive. To further complete the range of colours and special pieces, a new colour with a glossy finish and two new colours with a craquelé effect glaze have been introduced. All this completed with related special parts.



Dark Wine glossy - Ivroy glossy

Rivestimenti/Wall:
6,5x20 Vintage Finale Dark Wine Glossy - 20x20 Vintage Ottagono Ivory Glossy - 3x3 Vintage Tozzetto Dark Wine Glossy -
20x20 Vintage Zoccolo Dark Wine Glossy





Wine glossy - White glossy

Rivestimenti/Wall:

3,5x20 Vintage Bordura Dark Wine Glossy

10x20 Vintage White Glossy

10x20 Vintage Wine Glossy

20x20 Vintage White Glossy

20x20 Vintage Zoccolo Dark Wine Glossy

Pavimento/Floor:

20x20 Old England Ottagono Dover

4x4 Old England Tozzetto York



White Glossy

Rivestimenti/Wall:
20x20 Vintage Ottagono White Glossy - 3x3 Vintage Tozzetto White Glossy



White glossy - Black glossy

Rivestimenti/Wall:

10x20 Vintage Black Glossy - 6,5x20 Vintage Finale White Glossy - 2x6,5 Vintage Angolo Finale White Glossy - 20x20 Vintage Ottagono White Glossy- 3x3 Vintage Tozzetto Black Glossy - 20x20 Vintage Zoccolo White Glossy - 2x20 Vintage Angolo Zoccolo White Glossy - 1,2x20 Vintage Coprispigolo White Glossy

Pavimento/Floor:

20x20 Old England York - 33,7x33,7 Brera Mosaico Carbone



Black Glossy - Green Glossy

Rivestimenti/Wall:
6,5x20 Vintage Finale Black Glossy - 2x6,5 Vintage Angolo Finale Black Glossy - 10x20 Vintage Black Glossy - 10x20 Vintage Green Glossy - 1,2x20 Vintage Coprispigolo Green Glossy

Pavimento/Floor:
Brera Mosaico Tessere 7,3x7,3 Carbone + 2,4x2,4 Sale

Special Pieces



Finale
6,5x20 cm

1



Angolo finale
2x6,5 cm

2



Coprispigolo
1,2x20

3

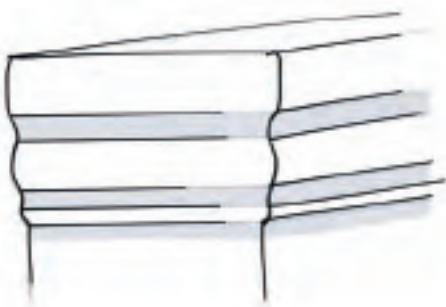

Vintage Glossy

Formato 20x20 / Size 20x20 7,87x7,87"

Spessore: ca. 10 mm / Thickness: ca. 0,4
117 Price List (mq)



20x20
White Glossy
VIN1



20x20
Ivory Glossy
VIN2

Formato Ottagono 20x20 / Size Ottagono 20x20 7,87x7,87"

Spessore: ca. 10 mm / Thickness: ca. 0,4
98 Price List (mq)



Ottagono
White Glossy
VOT1



Ottagono
Ivory Glossy
VOT2

Formato 10x20 / Size 10x20 3,94x7,87"

Spessore: ca. 10 mm / Thickness: ca. 0,4
98 Price List (mq) Color White Glossy / Ivory Glossy - 127 Price List (mq) All Other Colors

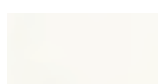

10x20
White Glossy
YY1

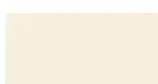

10x20
Ivory Glossy
YY2



10x20
Dove Glossy
YY3



10x20
Wine Glossy
YY5



10x20
Black Glossy
YY7



10x20
Green Glossy
YY8

* Pezzi smaltati su lato superiore / Pieces glazed on top

Formato Tozzetto 3x3 / Size Tozzetto 3x3 1,18x1,18"

8 Price List (pz)

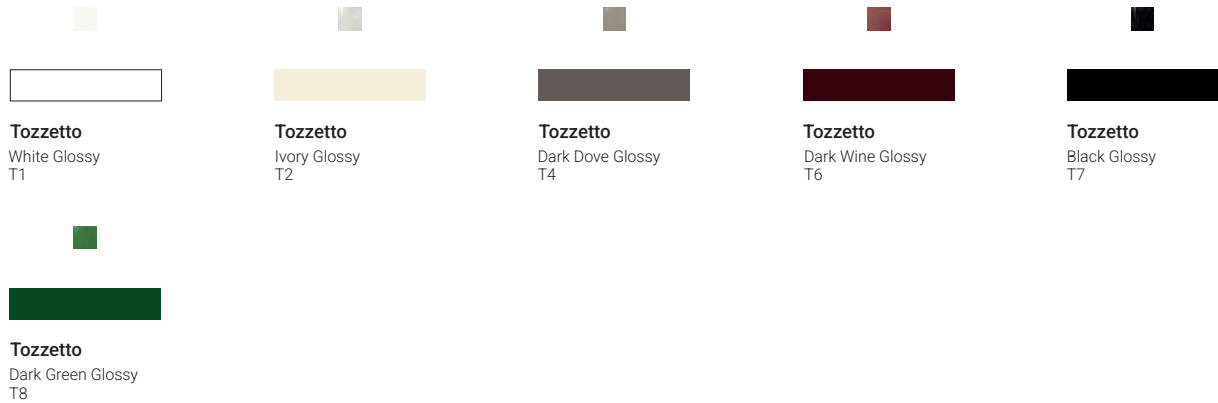

Pezzi speciali / Special pieces

Finale*

6,5x20 cm - 2,56x7,87"
105 Price List (pz)

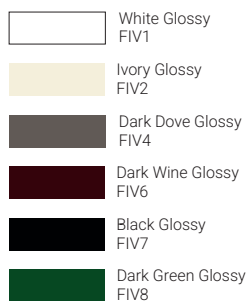

Tondo

2x20 cm - 0,79x7,87"
57 Price List (pz)

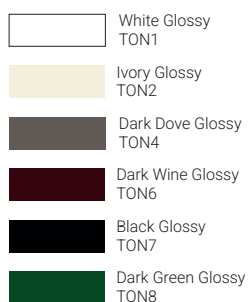

Angolo Finale*

2x6,5 cm - 0,79x2,56"
72 Price List (pz)

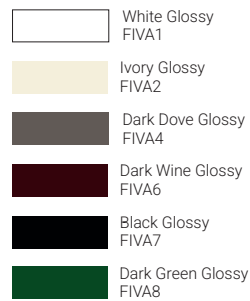

Zoccolo

20x20 cm - 7,87x7,87"
105 Price List (pz)



Bordura*

3,5x20 cm - 1,38x7,87"
55 Price List (pz)

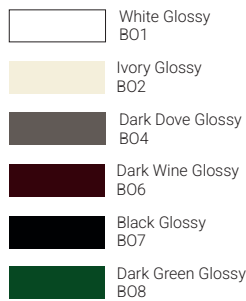

Angolo Zoccolo

2x20 cm - 0,79x7,87"
73 Price List (pz)

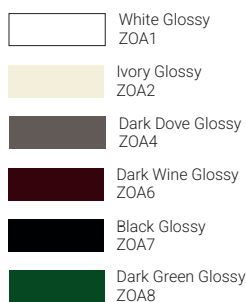

Angolo Bordura*

2x3,5 cm - 0,79x1,38"
105 Price List (pz)

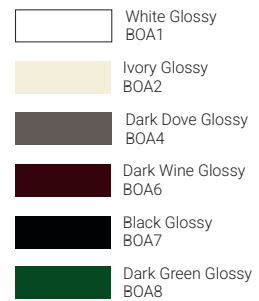

Coprispigo

1,2x20 cm - 0,47x7,87"
56 Price List (pz)



Vintage Craquelé

Formato 20x20 / Size 20x20 7,87x7,87"

Spessore: ca. 10 mm / Thickness: ca. 0,4
117 Price List (mq)

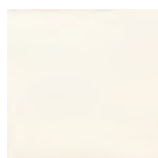

20x20
White Craquelé
VIN11



20x20
Ivory Craquelé
VIN12

Formato 10x20 / Size 10x20 3,94x7,87"

Spessore: ca. 10 mm / Thickness: ca. 0,4
98 Price List (mq)

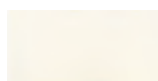

10x20
White Craquelé
YY11



10x20
Ivory Craquelé
YY12

Pezzi speciali / Special pieces

Finale*

6,5x20 cm - 2,56x7,87"
105 Price List (pz)





 White Craquelé
FIV11
 Ivory Craquelé
FIV12

Angolo Finale*

2x6,5 cm - 0,79x2,56"
72 Price List (pz)





 White Craquelé
FIVA11
 Ivory Craquelé
FIVA12

Bordura*

3,5x20 cm - 1,38x7,87"
55 Price List (pz)





 White Craquelé
BO11
 Ivory Craquelé
BO12

Angolo Bordura*

2x3,5 cm - 0,79x1,38"
105 Price List (pz)





 White Craquelé
BOA11
 Ivory Craquelé
BOA12

Tondo

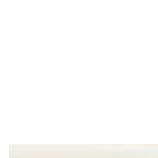
2x20 cm - 0,79x7,87"
57 Price List (pz)



 White Craquelé
TON11
 Ivory Craquelé
TON12

Zoccolo

20x20 cm - 7,87x7,87"
105 Price List (pz)





 White Craquelé
ZO11
 Ivory Craquelé
ZO12

Angolo Zoccolo

2x20 cm - 0,79x7,87"
73 Price List (pz)





 White Craquelé
ZOA11
 Ivory Craquelé
ZOA12

Coprispigolo

1,2x20 cm - 0,47x7,87"
56 Price List (pz)

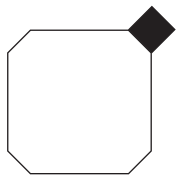

 White Craquelé
COV11
 Ivory Craquelé
COV12

Schemi di posa mosaici / Mosaics laying patterns20x20
Ottagono

1 mq. di ottagono richiede 25 pezzi di tozzetto
 1sqmt. octagon needs 25 pieces dots.

Lista imballaggi per box / Packing list per box

Descrizione / Description		kg box	pz. box	mq box	box pallet	kg. pallet
10x20	Formato 10x20	18,20	50	1,00	60	1.092
20x20	Formato 20x20	18,20	25	1,00	60	1.092
20x20	Formato Ottagono 20x20	18	25	0,96	60	1.092
20x20	Zoccolo	13,20	16	-	-	-
2x20	Angolo Zoccolo	1,95	30	-	-	-
3x3	Tozzetto	4,05	270	-	-	-
2x20	Tondo	5	52	-	-	-
6,5x20	Finale	11,55	32	-	-	-
2x6,5	Angolo Finale	1,60	40	-	-	-
3,5x20	Bordura	7,65	52	-	-	-
2x3,5	Angolo Bordura	8,85	60	-	-	-
1,2x20	Coprispigolo	0,85	21	-	-	-

* Pezzi smaltati su lato superiore / Pieces glazed on top

Si consiglia di trattare gli smalti craquelé con impregnante prima della stuccatura.
 We suggest to treat the crackle glazes with appropriate sealer before grouting.

New Classic

New classic, è una serie in bicottura tradizionale da rivestimento con superficie lucida. Formato rettangolare e con ottagono disponibile in diverse tonalità di colori neutri, da quest'anno arricchita dai nuovi matt anche nella superficie di Formae. Adatta a realizzazioni sia classiche che contemporanee, capace di rendere gli ambienti eleganti e sofisticati.

New classic is a double fired glossy wall tile. Rectangular with a matching octagon in several neutral colours, now enriched by the new matt colours also in Formae surface. Elegant and sophisticated, perfect for classic and modern interiors.



Beach Glossy

Rivestimenti/Wall:

13x26 New Classic Ottagono Beach Glossy - 3x3 New Classic Tozzetto Nero Glossy - 6x26 New Classic Festone Beach Glossy - 6,5x26 New Classic Toro Beach Glossy





Melissa Glossy - Agave Glossy

Rivestimenti/Wall:

- 13x26 New Classic Melissa Glossy
- 1,2x26 New Classic Coprispigo Melissa Glossy
- 13x26 New Classic Ottagono Agave Glossy
- 3x3 New Classic Tozzetto Melissa Glossy
- 6x26 New Classic Hellas Agave Glossy
- 6,5x26 New Classic Toro Agave Glossy

Grey Matt

Rivestimenti/Wall:
13x26 New Classic Ottagono Grey Matt
3x3 New Classic Tozzetto Ebony Matt





Ebony Matt

Rivestimenti/Wall:
13x26 New Classic Frame Ebony Matt









Agave Glossy

Rivestimenti/Wall:
13x26 New Classic Frame Agave Glossy



Designed by Architects - Agris Padelis-Lins

Parfume - Bianco

Rivestimenti/Wall:

13x26 New Classic Ottagono Parfume - 3x3 New Classic Tozzetto Bianco - 6.5x26 New Classic Toro Parfume

Special Pieces



Toro
6.5x26 cm



Tozzetto
3x3 cm

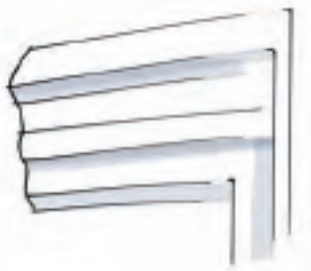

New Classic Glossy

Formato 13x26 / Size 13x26 5,12x10,24"

Spessore New Classic: ca. 10 mm / Thickness New Classic: ca. 0,4
68 Price List (mq) New Classic -

New Classic

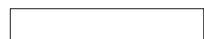
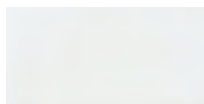

New Classic

Bianco Glossy
FZ1*

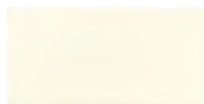

New Classic

Panna Glossy
FZ5*

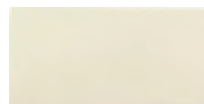

New Classic

Melissa Glossy
FZ6*

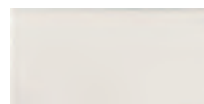

New Classic

Stone Glossy
FZ7*

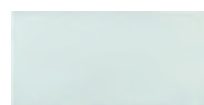

New Classic

Angel Glossy
FZ8*

Formato 13x26 / Size 13x26 5,12x10,24"

Spessore New Classic: ca. 11 mm / Thickness New Classic: ca. 0,4/0,43
91 Price List (mq) Frame

Frame



Frame

Bianco Glossy
FRA1



Frame

Beach Glossy
FRA5



Frame

Agave Glossy
FRA3

Formato ottagono 13x26 / Size octagon 13x26 5,12x10,24"

Spessore New Classic: ca. 10 mm / Thickness New Classic: ca. 0,4
98 Price List (mq) New Classic

New Classic

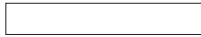
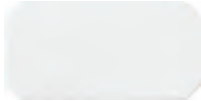

Ottagono
Bianco Glossy
OTT1*



Ottagono
Beach Glossy
OTT3*



Ottagono
Agave Glossy
OTT6*



Ottagono
Mauve Glossy
OTT7*



Ottagono
Parfume Glossy
OTT8*

Formato tozzetto 3x3 / Size tozzetto 3x3 1,18x1,18"

8 Price List (pz) New Classic

New Classic



Tozzetto
Bianco Glossy
T13

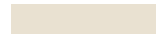

Tozzetto
Melissa Glossy
T400



Tozzetto
Panna Glossy
T500

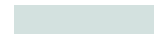

Tozzetto
Angel Glossy
T1000



Tozzetto
Stone Glossy
T900



Tozzetto
Nero Glossy
T18





New Classic Glossy

Pezzi speciali / Special pieces

Toro*

6,5x26 cm - 2,56x10,24"
58 Price List (pz)







	Bianco Glossy TOF1
	Beach Glossy TOF6
	Agave Glossy TOF4
	Mauve Glossy TOF70
	Parfume Glossy TOF80

Angolo toro*

2X6,5 cm - 0,79x2,56"
72 Price List (pz)







	Bianco Glossy TOFA1
	Beach Glossy TOFA6
	Agave Glossy TOFA4
	Mauve Glossy TOFA70
	Parfume Glossy TOFA80

Matita capitello

2x26 cm - 0,79x10,24"
56 Price List (pz)







	Bianco Glossy MA1
	Beach Glossy MA30
	Agave Glossy MA60
	Mauve Glossy MA70
	Parfume Glossy MA80

Zoccolo

20x26 cm - 7,87x10,24"
121 Price List (pz)







	Bianco Glossy ZO100
	Beach Glossy ZO600
	Agave Glossy ZO400
	Mauve Glossy ZO70
	Parfume Glossy ZO80

Angolo zoccolo

2X20 cm - 0,79x7,87"
73 Price List (pz)













	Bianco Glossy ZOA100
	Beach Glossy ZOA600
	Agave Glossy ZOA400
	Mauve Glossy ZOA70
	Parfume Glossy ZOA80

Coprispigolo

1,2x26 cm - 0,47x10,24"
19 Price List (pz)



	Bianco Glossy COPR1
	Angel Glossy COPR10
	Beach Glossy COPR30
	Panna Glossy COPR2
	Melissa Glossy COPR40
	Agave Glossy COPR60
	Stone Glossy COPR90
	Mauve Glossy COPR70
	Parfume Glossy COPR80
	Nero Glossy COPR100

* Pezzi smaltati su lato superiore / Pieces glazed on top

Pezzi speciali decorativi/ *Decorative special pieces*

New Classic

Hellas

7x26 cm - 2,76x10,24"
24 Price List (pz)



Bianco Glossy
HEL1



Beach Glossy
HEL3



Agave Glossy
HEL6



Mauve Glossy
HEL7



Perfume Glossy
HEL8

Festone

6x26 cm - 2,36x10,24"
24 Price List (pz)



Bianco Glossy
FEN1



Beach Glossy
FEN3



Agave Glossy
FEN6



Mauve Glossy
FEN7



Perfume Glossy
FEN8

New Classic Matt

Formato 13x26 / Size 13x26 5,12x10,24"

Spessore New Classic: ca. 10 mm / Thickness New Classic: ca. "0,4
68 Price List (mq) New Classic

New Classic

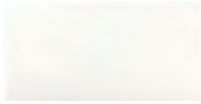

New Classic

Cotton Matt
FZ11



New Classic

Grey Matt
FZ12



New Classic

Light Navy Matt
FZ13



New Classic

Ebony Matt
FZ14

Formato 13x26 / Size 13x26 5,12x10,24"

Spessore New Classic: ca. 10 mm / Thickness New Classic: ca. "0,4
91 Price List (mq) New Classic

Formae



Frame

Cotton Matt
FRA11



Frame

Grey Matt
FRA12



Frame

Light Navy Matt
FRA13

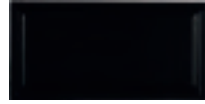

Frame

Ebony Matt
FRA14

Formato ottagono 13x26 / Size octagon 13x26 5,12x10,24"

Spessore New Classic: ca. 10 mm / Thickness New Classic: ca. "0,4
98 Price List (mq) New Classic

New Classic



Ottagono

Cotton Matt
OTT11



Ottagono

Grey Matt
OTT12



Ottagono

Light Navy Matt
OTT13



Ottagono

Ebony Matt
OTT14

Formato tozzetto 3x3 / Size tozzetto 3x3 1,18x1,18"

8 Price List (pz) New Classic

New Classic



Tozzetto

Cotton Matt
T110



Tozzetto

Grey Matt
T120



Tozzetto

Light Navy Matt
T130



Tozzetto

Ebony Matt
T140





Pezzi speciali / *Special pieces*

New Classic

Toro*

6,5x26 cm - 2,56x10,24"
58 Price List (pz)







	Cotton Matt TOF110
	Grey Matt TOF120
	Light Navy Matt TOF130
	Ebony Matt TOF140

Angolo toro*

2X6,5 cm - 0,79x2,56"
72 Price List (pz)







	Cotton Matt TOFA110
	Grey Matt TOFA120
	Light Navy Matt TOFA130
	Ebony Matt TOFA140

Matita capitello

2x26 cm - 0,79x10,24"
56 Price List (pz)







	Cotton Matt MA110
	Grey Matt MA120
	Light Navy Matt MA130
	Ebony Matt MA140

Zoccolo

20x26 cm - 7,87x10,24"
121 Price List (pz)







	Cotton Matt ZO110
	Grey Matt ZO120
	Light Navy Matt ZO130
	Ebony Matt ZO140

Angolo zoccolo

2X20 cm - 0,79x7,87"
73 Price List (pz)







	Cotton Matt ZOA110
	Grey Matt ZOA120
	Light Navy Matt ZOA130
	Ebony Matt ZOA140

Coprispigolo

1,2x26 cm - 0,47x10,24"
19 Price List (pz)



	Cotton Matt COPR110
	Grey Matt COPR120
	Light Navy Matt COPR130
	Ebony Matt COPR140

* Pezzi smaltati su lato superiore / Pieces glazed on top

New Classic



Ebony Matt

Rivestimenti/Wall:
13x26 New Classic Frame Ebony Matt

Lista imballaggi per box / Packing list per box

Descrizione / Description		kg box	pz.box	mq box	box pallet	kg. pallet
New Classic						
13x26	Formato 13x26	8,95	15	0,507	114	1.020
13x26	Formato 13x26 Frame	8,95	15	0,507	114	1020
13x26	Formato Ottagono	8,85	15	0,493	114	1.009
3x3	Formato Tozzetto	2,7	270	-	-	-
6x26	Festone	7,5	30	-	-	-
7x26	Hellas	2	20	-	-	-
6,5x26	Toro	7	20	-	-	-
2x6,5	Angolo Toro	1,6	40	-	-	-
20x26	Zoccolo	10	10	-	-	-
2x20	Angolo Zoccolo	1,9	30	-	-	-
2x26	Matita Capitello	4,5	36	-	-	-
1,2x26	Coprispigolo	0,85	21	-	-	-

Formelle

Formelle, classiche strutture. Bicottura tradizionale in pasta bianca da rivestimento con superficie lucida e craquelé. La serie è costituita da 3 diverse decorazioni a rilievo, adatte per formare pareti decorate a contrasto. In formato 13x13: Milano, rilievo 3D architettonico dal sapore contemporaneo, Algarve rilievo tradizionale e Anversa ispirato al classico decoro olandese "Delft".

Formelle, classic textures. Double fired white bodied wall tile with a glossy and craquele finish. The range has 3 relief decors in 13x13 size: Milano, a 3D architectural style, Algarve, a traditional design, and Anversa, a modern reinterpretation of the classic DutchDelftdecor.



Designed by Lyudmila Koroleva, ITACOM furniture

Argento craquelè

Rivestimenti/Wall:
13x13 Formelle Milano Argento Craquelè

Argento craquelè

Rivestimenti/Wall:
13x13 Formelle Milano Argento Craquelè

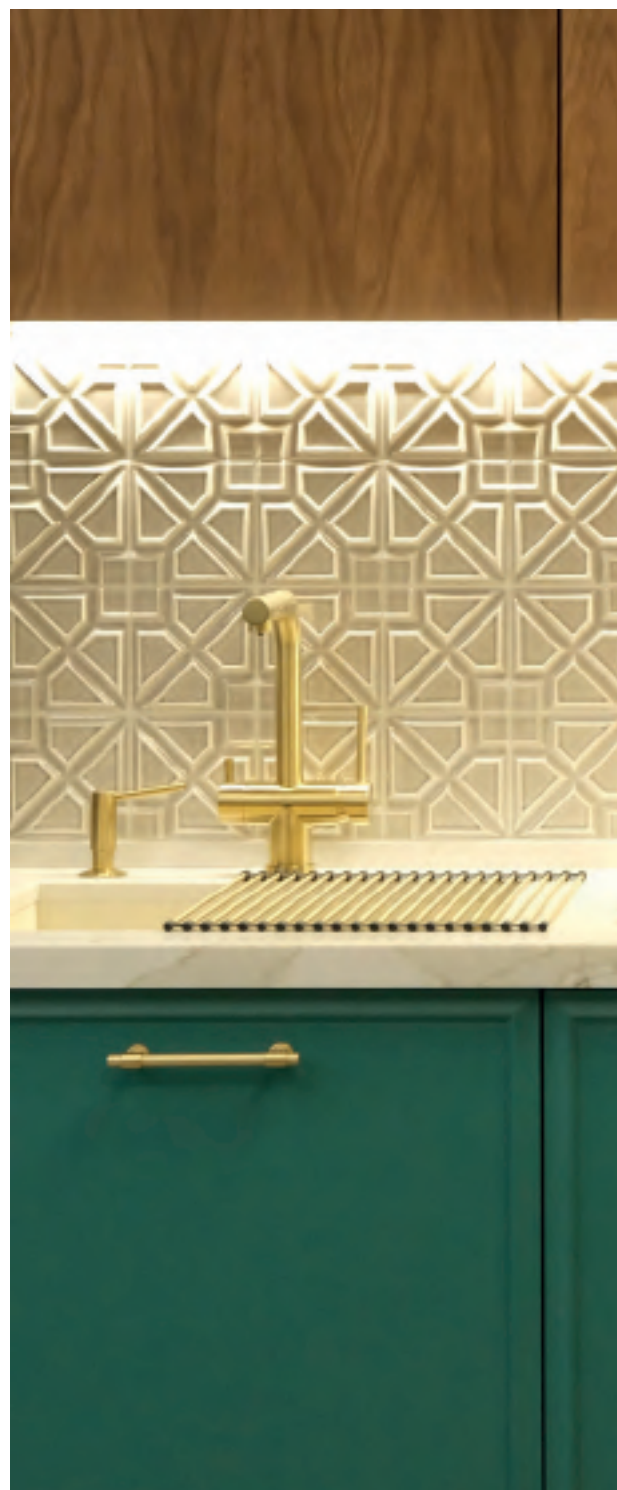

Designed by Lyudmila Koroleva, ITACOM furniture





Greige craquelè

Rivestimenti/Wall:
13x13 Formelle Milano Greige Craquelè

Pavimento/Floor:
30x30 Brera Carbone - 30x30 Brera Sabbia



Cotto Glossy

Rivestimenti/Wall:
13x13 Formelle Milano Cotto Glossy





Cielo Glossy

Rivestimenti/Wall:
13x13 Formelle Anversa Cielo Glossy

Designed by Dasha Kossa interior designer - project Fairy Countryside



Cielo Glossy

Rivestimenti/Wall:
13x13 Formelle Anversa Cielo Glossy



Cielo Glossy

Rivestimenti/Wall:
13x13 Formelle Anversa Cielo Glossy

Cielo Glossy

Rivestimenti/Wall:
13x13 Formelle Anversa Cielo Glossy



Designed by Dasha Kossa interior designer - project Fairy Countryside







Cielo Glossy

Rivestimenti/Wall:

13x13 Formelle Anversa Cielo Glossy

6,5x13 Melange Milk Glossy

1,2x26 Melange Coprispigolo Milk Glossy

Pavimento/Floor:

30x30 Brera Cielo

30x30 Brera Carbone



Designed by Tatiana Zhuravleva interior designer

Timo Craquelè

Rivestimenti/Wall:

13x13 Formelle Algarve Timo Craquelè - 6,5x13 Essenze Finale Ice Glossy - 6,5x2 Essenze Angolo Capitello Ice Glossy - 13x13 Essenze Ice Glossy - 1,2x26 Essenze Coprispigolo Ice Glossy

Pavimento/Floor:

30x30 Brera Sale - 30x30 Brera Tortora



Designed by Tatiana Zhuravleva interior designer

Timo Craquelè

Rivestimenti/Wall:

13x13 Formelle Algarve Timo Craquelè - 6,5x13 Essenze Finale Ice Glossy - 6,5x2 Essenze Angolo Capitello Ice Glossy - 13x13 Essenze Ice Glossy - 1,2x26 Essenze Coprispigolo Ice Glossy

Pavimento/Floor:

30x30 Brera Sale - 30x30 Brera Tortora

Timo Craquelè

Rivestimenti/Wall:

13x13 Formelle Algarve Timo Craquelè

6,5x13 Essenze Finale Ice Glossy

6,5x2 Essenze Angolo Capitello Ice Glossy

13x13 Essenze Ice Glossy

1,2x26 Essenze Coprispigolo Ice Glossy

Pavimento/Floor:

30x30 Brera Sale

7,3x7,3 Brera Tozzetto Cassettone Sale

7,3x30 Brera Listello Cassettone Salvia







Ambra Craquelè

Rivestimenti/Wall:

5,5x26 Melange Toro Butter Glossy - 5,5x2 Melange Ang Est Toro Butter Glossy - 13x13 Melange Butter Glossy - 2x26 Melange Matita Capitello Butter Glossy - 1,2x26 Melange Coprispigolo Butter Glossy - 13x13 Formelle Algarve Ambra Craquele

Special Pieces



Toro Melange
5,5x26 cm

1



Angolo Est. Toro Melange
5,5X2 cm

2



Matita Capitello Melange
2x26 cm

3



Coprispigo Melange
1,2X26 cm

4

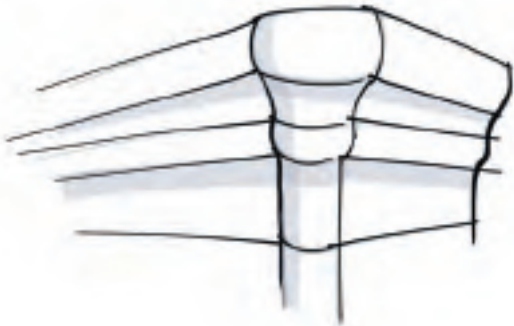

Formelle Glossy

Formato 13x13 / Size 13x13 5,12x5,12"

Spessore Milano e Algarve: ca. 9/13 mm / Thickness Milano e Algarve: ca. *0,35/0,5
 Spessore Anversa: ca. 9/10 mm / Thickness Anversa: ca. *0,35/0,4
 133 Price List (mq) Milano e Algarve - 130 Price List (mq) Anversa

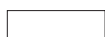

Milano
 Bianco Glossy
 MILA1



Milano
 Cotto Glossy
 MILA8



Algarve
 Bianco Glossy
 ALGA1



Algarve
 Cotto Glossy
 ALGA8

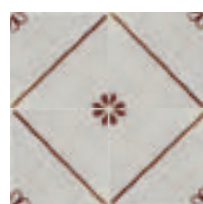

Anversa
 Timo Glossy
 ANV4



Anversa
 Argento Glossy
 ANV5



Anversa
 Cielo Glossy
 ANV6



Anversa
 Topazio Glossy
 ANV7



Anversa
 Cotto Glossy
 ANV8

Formelle Craquelé

Formato 13x13 / Size 13x13 5,12x5,12"

Spessore Milano e Algarve: ca. 9/13 mm / Thickness Milano e Algarve: ca. *0,35/0,5
133 Price List (mq)



Milano
Ambra Craquelé
MILA2



Milano
Greige Craquelé
MILA3



Milano
Timo Craquelé
MILA4



Milano
Argento Craquelé
MILA5



Milano
Cielo Craquelé
MILA6



Milano
Topazio Craquelé
MILA7



Algarve
Ambra Craquelé
ALGA2



Algarve
Greige Craquelé
ALGA3



Algarve
Timo Craquelé
ALGA4



Algarve
Argento Craquelé
ALGA5



Algarve
Cielo Craquelé
ALGA6



Algarve
Topazio Craquelé
ALGA7

Lista imballaggi per box / Packing list per box

Descrizione / Description		kg box	pz.box	mq box	box pallet	kg. pallet
13x13	Formato 13x13 Milano	7,72	24	0,406	114	880
13x13	Formato 13x13 Algarve	7,617	24	0,406	114	868
13x13	Formato 13x13 Anversa	7,7	28	0,473	114	878

Si consiglia di trattare gli smalti craquelé con impregnante prima della stuccatura.
We suggest to treat the crackle glazes with appropriate sealer before grouting.

Shades of Art

Rivestimento artigianale che risalta l'unicità di ogni mattonella creando superfici originali dal gusto rustico e tradizionale. Si inserisce molto bene anche in ambienti contemporanei, per creare piacevoli contrasti di design.

Handmade wall tiles that highlights the uniqueness of each piece creating original surfaces with a rustic and traditional taste. It fits very well even in contemporary environments, to create pleasant design contrasts.



Charcoal Glossy

Rivestimenti/Wall:
13x13 Shades of Art Charcoal Glossy





Jade Glossy

Rivestimenti/Wall:

2x26 Shades Of Art Top Jade Glossy

13x13 Shades Of Art Jade Glossy

13x13 Shades Of Art Zoccolo Jade Glossy

Pavimento/Floor:

20x20 Old England Bath

20x20 Althaus Giralda Sand Bath



Sand Glossy

Rivestimenti/Wall:

13x13 Shades Of Art Sand Glossy - 1,2x26 Shades Of Art Cosprispigolo Sand Glossy - 13x13 Shades Of Art Giralda Sand Glossy



Jade Glossy

Rivestimenti/Wall:

13x13 Shades Of Art Alcazar Jade Glossy - 2x26 Shades Of Art Top Jade Glossy - 13x13 Shades Of Art Jade Glossy



Denim Glossy

Rivestimenti/Wall:

13x13 Shades Of Art Denim Glossy - 1,2x26 Shades Of Art Coprispigolo Denim Glossy - 7x13 Shades Of Art Finale Denim Glossy
2x7 Shades Of Art Angolo Finale Denim Glossy

Special Pieces



Coprispigolo
1,2x26 cm



Finale Capitello
7x13 cm



Angolo Finale Est.
2x7 cm

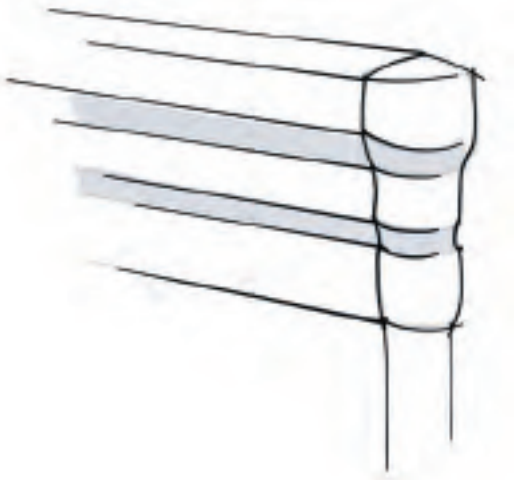

Shades of Art Glossy

Formato 13x13 / Size 13x13 5,12x5,12"

Spessore: ca. 11 mm / Thickness: ca. 0,4
132 Price List (mq)



13x13
Alabaster Glossy
SHA1



13x13
Sand Glossy
SHA2



13x13
Gravel Glossy
SHA6



13x13
Jade Glossy
SHA4



13x13
Denim Glossy
SHA3



13x13
Charcoal Glossy
SHA5

Pezzi speciali / Special pieces

Finale Capitello

7x13 cm - 2,76x5,12"
45 Price List (pz)

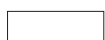

- Alabaster Glossy FIS1
- Sand Glossy FIS2
- Gravel Glossy FIS6
- Jade Glossy FIS4
- Denim Glossy FIS3
- Charcoal Glossy FIS5

Angolo Finale est.

2x7 cm - 0,79x2,76"
74 Price List (pz)

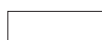

- Alabaster Glossy FISA1
- Sand Glossy FISA2
- Gravel Glossy FISA6
- Jade Glossy FISA4
- Denim Glossy FISA3
- Charcoal Glossy FISA5

Zoccolo

13x13 cm - 5,12x5,12"
118 Price List (pz)

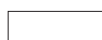

- Alabaster Glossy ZOS1
- Sand Glossy ZOS2
- Gravel Glossy ZOS6
- Jade Glossy ZOS4
- Denim Glossy ZOS3
- Charcoal Glossy ZOS5

Angolo Zoccolo

1,7x13 cm - 0,67x5,12"
74 Price List (pz)



- Alabaster Glossy ZOSA1
- Sand Glossy ZOSA2
- Gravel Glossy ZOSA6
- Jade Glossy ZOSA4
- Denim Glossy ZOSA3
- Charcoal Glossy ZOSA5

Top

2x26 cm - 0,79x10,24"
57 Price List (pz)



- Alabaster Glossy TOSA1
- Sand Glossy TOSA2
- Gravel Glossy TOSA6
- Jade Glossy TOSA4
- Denim Glossy TOSA3
- Charcoal Glossy TOSA5

Coprispigolo

1,2x26 cm - 0,47x10,24"
56 Price List (pz)



- Alabaster Glossy COSA1
- Sand Glossy COSA2
- Gravel Glossy COSA6
- Jade Glossy COSA4
- Denim Glossy COSA3
- Charcoal Glossy COSA5

Decoro / Decoration

Alcazar

13x13 cm - 5,12x5,12"

133 Price List (mq)



13x13
Alabaster Glossy
ALCA1



13x13
Sand Glossy
ALCA2



13x13
Gravel Glossy
ALCA6



13x13
Jade Glossy
ALCA4



13x13
Denim Glossy
ALCA3



13x13
Charcoal Glossy
ALCA5

Giralda

13x13 cm - 5,12x5,12"

133 Price List (mq)

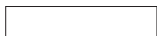

13x13
Alabaster Glossy
GIRA1



13x13
Sand Glossy
GIRA2



13x13
Gravel Glossy
GIRA6



13x13
Jade Glossy
GIRA4



13x13
Denim Glossy
GIRA3



13x13
Charcoal Glossy
GIRA5

Shades of Art



Sand Glossy

Rivestimenti/Wall:

13x13 Shades Of Art Sand Glossy - 2x26 Shades Of Art Top Sand Glossy - 13x13 Shades Of Art Giralda Sand Glossy

Lista imballaggi per box / Packing list per box

Descrizione / Description		kg box	pz.box	mq.box	box pallet	kg pallet
13x13	Formato 13x13	24	114	0,4056	114	953
13x13	Alcazar	24	114	0,4056	114	935
13x13	Giralda	24	114	0,4056	114	926
13x13	Zoccolo	24	16	-	-	-
1,7x13	Angolo Zoccolo	1	28	-	-	-
7x13	Finale	6	36	-	-	-
2x7	Angolo Finale	0,99	48	-	-	-
1,2x26	Coprispigolo	0,5	24	-	-	-
2x26	Top	2	35	-	-	-

The Boiserie

Caratteristiche Tecniche / *Technical Features*

	Normativa / Standard	Valore Richiesto / Required Standards	Ceramiche Grazia
assorbimento d'acqua <i>water absorption</i>	UNI-EN ISO 10545-3	> 10 %	conforme <i>conforming</i>
resistenza dei colori alla luce <i>colour resistance to light</i>	DIN 51094	-	
resistenza al cavillo* <i>crazing resistance*</i>	UNI-EN ISO 10545-11	-	resistente <i>resistant</i>
resistenza chimica* <i>resistance to chemical attack*</i>	UNI-EN ISO 10545-13	classe B <i>class B</i>	garantita <i>unaffected</i>
piombo e cadmio rilasciati <i>lead and cadmium release</i>	UNI-EN ISO 10545-15	metodo disponibile <i>test method available</i>	metodo disponibile <i>test method available</i>
reazione al fuoco <i>reaction to fire</i>	EN 13501-1	-	A1-A1_{FL}
variazione di tono <i>shade variation</i>	-	-	V2

***Eccetto per i prodotti craquelè perché non testabile / *Except for craquelè products because not testable**

PIASTRELLE CERAMICHE IN BICOTTURA / DOUBLE FIRED CERAMIC TILES

Piastrelle di ceramica pressate a secco con assorbimento $E_b \geq 10\%$.

Caratteristiche di qualità secondo i test di controllo previsti dalla norma EN 14411:2012 appendice K gruppo BIII GL /
Dry-pressed ceramic tiles with water absorption $E_b \geq 10\%$.

Quality characteristics according to reference control test from standards EN 14411:2012 annex K group BIII GL

Rivestimenti

Caratteristiche Tecniche / *Technical Features*

	Normativa / Standard	Valore Richiesto / Required Standards	Ceramiche Grazia
assorbimento d'acqua <i>water absorption</i>	UNI-EN ISO 10545-3	> 10 %	conforme <i>conforming</i>
resistenza dei colori alla luce <i>colour resistance to light</i>	DIN 51094	-	
resistenza al cavillo* <i>crazing resistance*</i>	UNI-EN ISO 10545-11	-	resistente <i>resistant</i>
resistenza chimica* <i>resistance to chemical attack*</i>	UNI-EN ISO 10545-13	classe B <i>class B</i>	garantita <i>unaffected</i>
piombo e cadmio rilasciati <i>lead and cadmium release</i>	UNI-EN ISO 10545-15	metodo disponibile <i>test method available</i>	metodo disponibile <i>test method available</i>
reazione al fuoco <i>reaction to fire</i>	EN 13501-1		A1-A1_{FL}
variazione di tono <i>shade variation</i>	-	-	V2

**Eccetto per i prodotti craquelè perché non testabile / *Except for craquelè products because not testable*

PIASTRELLE CERAMICHE IN BICOTTURA / DOUBLE FIRED CERAMIC TILES

Piastrelle di ceramica pressate a secco con assorbimento $E_b \geq 10\%$.

Caratteristiche di qualità secondo i test di controllo previsti dalla norma EN 14411:2012 appendice K gruppo BIII GL /
Dry-pressed ceramic tiles with water absorption $E_b \geq 10\%$.

Quality characteristics according to reference control test from standards EN 14411:2012 annex K group BIII GL

Gres Porcellanato

Caratteristiche Tecniche / *Technical Features*

	Normativa / Standard	Valore Richiesto / Required Standards	Ceramiche Grazia
dimensioni <i>dimensions</i>			
lunghezza e larghezza <i>length and width</i>	UNI-EN ISO 10545-2	± 0,6 %	conforme <i>conforming</i>
dimensioni : spessore <i>size : thickness</i>	UNI-EN ISO 10545-2	± 5 %	conforme <i>conforming</i>
rettilineità dei lati <i>straightness of sides</i>	UNI-EN ISO 10545-2	± 0,5 %	conforme <i>conforming</i>
ortogonalità <i>rectangularity</i>	UNI-EN ISO 10545-2	± 0,5 %	conforme <i>conforming</i>
planarità - svergolamento <i>surface flatness</i>	UNI-EN ISO 10545-2	± 0,5 %	conforme <i>conforming</i>
resistenza alla flessione : <i>resistance of rupture :</i>			
carico di rottura <i>breaking strength</i>	UNI-EN ISO 10545-4	> 1300 N (≥ 7,5 mm) > 700 N (< 7,5 mm)	conforme <i>conforming</i>
modulo di rottura <i>modulus of rupture</i>	UNI-EN ISO 10545-4	> 35 N/mm ² (≥ 7,5 mm)	conforme <i>conforming</i>
resistenza all'abrasione profonda <i>abrasion resistance</i>	UNI-EN ISO 10545-6	MAX 175 mm ³	conforme <i>conforming</i>
resistenza all'abrasione <i>abrasion resistance</i>	UNI-EN ISO 10545-7	-	pei iv (6000 giri)
assorbimento d'acqua <i>water absorption</i>	UNI-EN ISO 10545-3	≤ 0,5 %	conforme <i>conforming</i>
resistenza dei colori alla luce <i>colour resistance to light</i>	DIN 51094	-	
resistenza agli sbalzi termici <i>thermal shock resistance</i>	UNI-EN ISO 10545-9	-	resistente <i>resistant</i>
resistenza al gelo <i>frost resistance</i>	UNI-EN ISO 10545-12	-	resistente <i>resistant</i>
resistenza al cavillo <i>crazing resistance*</i>	UNI-EN ISO 10545-11	-	resistente <i>resistant</i>
resistenza alle macchie <i>resistance to stains</i>	UNI-EN ISO 10545-14	classe 3 min. <i>class 3 min.</i>	classe 5 <i>class 5</i>
resistenza chimica <i>resistance to chemical attack*</i>	UNI-EN ISO 10545-13	GB min. <i>GB min.</i>	garantita <i>unaffected</i>

piombo e cadmio rilasciati <i>lead and cadmium release</i>	UNI-EN ISO 10545-15	metodo disponibile <i>test method available</i>	metodo disponibile <i>test method available</i>
scivolosità <i>slipperiness</i>	DIN EN 16165:2023-02	-	R10
scivolosità (pendulum test) <i>slipperiness (pendulum test)</i>	BS 7976-2	-	40 bagnato <i>40 wet</i>
scivolosità di superfici bagnate a piedi nudi <i>slipperiness on wet surfaces barefoot</i>	DIN51097	-	B
reazione al fuoco <i>reaction to fire</i>	EN 13501-1	-	A1-A1_{FL}
variazione di tono <i>shade variation</i>	-	-	V2

GRES PORCELLANATO / PORCELAIN TILES

Piastrelle di ceramica pressate a secco con assorbimento $E_b \geq 0,5\%$.

Caratteristiche di qualità secondo i test di controllo previsti dalla norma EN14411:2012 appendice G gruppo BI_a GL - BI_a UGL

Dry-pressed ceramic tiles with water absorption $E_b \geq 0,5\%$.

Quality specification according to control test of 14411:2012 appendix G group BI_a GL - BI_a UGL

Condizioni generali di vendita

Premessa: nel testo seguente Ceramiche Grazia S.p.A. verrà designata "Venditrice", la controparte contrattuale come "Acquirente"

- 1) - OGGETTO - La vendita riguarda esclusivamente i materiali ed i quantitativi specificati nella conferma d'ordine o in altre comunicazioni scritte provenienti dalla Venditrice.
- 2) - NORMATIVA CONTRATTUALE - Le presenti condizioni generali, salvo eventuali modificazioni concordate per iscritto disciplinano tutti i contratti di vendita conclusi con la Venditrice e concernenti i prodotti compresi nei suoi cataloghi. Dette condizioni, apposte su tutti i cataloghi della Venditrice con l'elenco ed i prezzi della merce, si intendono conosciute dagli acquirenti, e quindi efficaci nei loro confronti nel momento in cui prendono visione del catalogo. Qualsiasi deroga alle presenti condizioni generali, anche se effettuata su iniziativa degli agenti della Venditrice, sarà vincolante per la Venditrice solo dopo la sua eventuale accettazione per iscritto e comunque limitata al singolo contratto cui si riferisce.
- 3) - CONFERMA D'ORDINE - Il contratto di vendita si perfezionerà con il ricevimento, da parte del Compratore, della conferma d'ordine della Venditrice. Le offerte fatte ai clienti dagli agenti, da procuratori o da altri intermediari e le proposte d'ordine da essi inoltrate, non vincoleranno la Venditrice sino all'accettazione espressa con la predetta conferma d'ordine. Tale conferma d'ordine prevarrà sul testo eventualmente difforme dell'offerta o dell'accettazione e sarà vincolante per l'acquirente qualora non ne abbia contestato la conformità per iscritto entro due giorni dal ricevimento della conferma d'ordine stessa.
- 4) - CONSEGNA - la merce si intende venduta "franco fabbrica" e la consegna s'intende eseguita negli stabilimenti della Venditrice dopo dieci giorni dalla notifica dell'appuntamento o, in difetto, all'atto della rimessione al vettore o all'atto della firma della bolla di accompagnamento da tale momento tutti i rischi del materiale si trasferiscono all'Acquirente. L'Acquirente dovrà inoltre sostenere le spese di magazzino e custodia qualora la merce si trovi depositata presso terzi e non venga ritirata tempestivamente: I termini di consegna si intendono approssimativi: anche quelli espressamente dichiarati perentori sono soggetti alle tolleranze d'uso e sono prorogati per effetto di avvenimenti non imputabili alla Venditrice. Tutte le spedizioni per ferrovie ed automezzo saranno effettuate in porto assegnato. Le spedizioni via mare e via terra concernenti forniture all'estero saranno effettuate in base alle condizioni scelte di volta in volta approvate dalla camera di Commercio Internazionale e successive modifiche ("Incoterms").
- 5) - I PREZZI SI INTENDONO FRANCO FABBRICA - Tasse, imposte e spese di ogni genere sono a carico dell'Acquirente. La merce ai fini della fatturazione e dei relativi pagamenti verrà quantificata sulla base dell'effettiva quantità fornita. La Venditrice potrà modificare i prezzi del materiale qualora tra l'acquisizione dell'ordine e la consegna si verificano aumenti superiori del 10% della manodopera e delle materie prime. Luogo del pagamento è la sola sede della Venditrice, la quale ha la facoltà di accettare cambiali, assegni bancari, autorizzazioni di tratte senza che questo comporti la novazione del credito originale, pregiudizio al patto di riservato dominio, mutamento nella deroga alla competenza territoriale. Non sono riconosciuti pagamenti effettuati ad Agenti, Rappresentanti, o altri soggetti che non siano la Venditrice salvo espressa deroga per iscritto da parte di quest'ultima conferita caso per caso. Qualsiasi ritardo o irregolarità nei pagamenti dà alla Venditrice il diritto di risolvere i contratti in corso o di sospendere le consegne o di pretendere il pagamento anticipato, con immediata decadenza dal beneficio del termine, anche se si tratti di contratti diversi, nonché il diritto al risarcimento degli eventuali danni senza alcun diritto per l'Acquirente di avanzare pretese di indennizzi o altro. Il ritardo nei pagamenti, anche parziale, rispetto ai termini di contratto o, in mancanza, ai termini legali di cui all'art. 4 del Dlgs 231/2002, farà decorrere automaticamente, senza che sia necessaria la costituzione in mora, gli interessi nella misura prevista dell'art. 5, comma 1 e 2, del DLGS 231/2002. Sarà, inoltre, dovuto alla venditrice il rimborso dei costi di recupero delle somme non tempestivamente pagate come previsto dall'art. 6 del medesimo decreto secondo le tariffe forensi in materia stragiudiziale. Qualora il recupero delle somme avvenga in via giudiziale si applicano gli artt. 633 e seguenti del c.p.c. secondo le modifiche apportate dal Dlgs 231/2002.
- 6) - GARANZIA - La Venditrice fornisce la garanzia solo per il materiale di prima scelta con una tolleranza del 5%; è espressamente esclusa la garanzia per la seconda e terza scelta e per gli stocks. Le eventuali differenze di tonalità e le volute imperfezioni dei decori sono una caratteristica ed un pregio della produzione artistica, anche la presenza di cavillature (craquelé) sulla superficie smaltata costituisce un fenomeno proprio delle ceramiche artistiche e tende a risultare meno evidente con un'adeguata pulizia. Vizi e difetti della merce dovranno essere denunciati nei termini di legge e, qualora accertati e riconosciuti dalla Venditrice, daranno diritto alla sostituzione del materiale. Resta esclusa la possibilità di richiedere la risoluzione del contratto ed il risarcimento dei danni diretti o indiretti dovuti questi ultimi alla mancata disponibilità del materiale durante il periodo necessario per la sua sostituzione. Sono a carico dell'acquirente le spese di trasporto, assicurazione e montaggio del materiale inviato in sostituzione. La Venditrice rimane proprietaria del materiale sostituito che deve essere ritornato presso i suoi stabilimenti entro trenta giorni dalla spedizione del nuovo materiale. Rimane esclusa dalla presente garanzia la merce che sia già stata posata e la merce che sia stata trattata con soluzioni a base di acido e quindi non adeguate. È sempre esclusa la garanzia per quel che riguarda l'uso che verrà fatto, anche se la Venditrice ha fornito pareri o suggerimenti.
- 7) - CARATTERISTICHE DEL MATERIALE - La colorazione del materiale, lo spessore, la forma e le ambientazioni realizzate e facenti parte di dépliant, listini preventivi e altro materiale pubblicitario, hanno solo scopo illustrativo e sono puramente indicativi; non sono vincolanti per la Venditrice, la quale si riserva in qualsiasi momento di modificarli secondo le proprie esigenze commerciali e di produzione. Per quanto riguarda la posa dei materiali e la loro pulizia, si fa riferimento ai consigli di posa contenuti nel presente catalogo, che si intendono vincolanti per la corretta manutenzione ed installazione degli stessi.
- 8) - DIVIETO DI AZIONE - L'Acquirente non può per nessuna ragione ritardare o sospendere i pagamenti, anche in presenza di contestazioni o reclami, né può promuovere le azioni giudiziali nei confronti della Venditrice se prima non ha provveduto all'integrale estinzione del debito.
- 9) - PATTO DI RISERVATO DOMINIO - In caso di vendita a pagamento dilazionato la Venditrice rimane proprietaria del materiale sino all'integrale pagamento del debito da parte dell'acquirente.
- 10) - MODIFICHE CONTRATTUALI - Qualsiasi modifica alle presenti condizioni generali dovrà essere apportata per iscritto o confermata con lettera raccomandata dalla Venditrice.
- 11) - LA RISOLUZIONE DELLE CONTROVERSIE - È demandata alla competenza dell'Autorità Giudiziaria di Modena, salva la facoltà della venditrice di adire a sua scelta l'Autorità Giudiziaria del luogo di residenza o domicilio dell'Acquirente. In caso di forniture all'estero le controversie che dovessero insorgere saranno regolate dalla legge italiana.
- 12) - TRATTAMENTO DEI DATI PERSONALI - Ai sensi dell'art. 10 della legge 31 dicembre 1996 numero 675, la Venditrice informa l'Acquirente che i dati personali da questo forniti, ovvero altrimenti acquisiti dalla Venditrice nell'ambito della propria attività anche presso società che offrono servizi di informazione commerciale, potranno formare oggetto di trattamento, nel rispetto della normativa sopra richiamata e degli obblighi di riservatezza ai quali la Venditrice è tenuta. Per trattamento dei dati personali si intende la loro raccolta, registrazione, organizzazione, conservazione, elaborazione, modificazione, selezione, estrazione, raffronto, utilizzo, interconnessione, blocco, comunicazioni, diffusione, cancellazione e distruzione ovvero la combinazione di due o più di tali operazioni. I dati di cui trattasi verranno trattati per finalità connesse e strumentali all'attività della Venditrice. In relazione ai predetti trattamenti l'Acquirente potrà esercitare i diritti di cui all'art.13 della legge 675/96 il conferimento dei dati, pur non essendo obbligatorio, è tuttavia necessario in quanto strettamente funzionale allo svolgimento dei contratti regolati dalle presenti condizioni generali di vendita per cui il mancato consenso da parte dell'Acquirente al trattamento dei dati comporterà, ove inevitabile per la qualità dei dati di cui è negato il trattamento o il consenso alla comunicazione, la risoluzione dei contratti o l'impossibilità di darvi corso. Il titolare dei sopracitati trattamenti è Ceramiche Grazia S.p.A. con sede legale e amministrativa in Corlo Formigine (MO) Italy nella persona del legale rappresentante ai fini della legge 675/96.

General sales conditions

Premise: in the following text Ceramiche Grazia S.p.A. will be designated "Seller" and the contractual counterparty "Buyer"

- 1) - SUBJECT - The sale concerns only the materials and quantities specified in the order confirmation or in other written communications from the Seller.
- 2) - CONTRACTUAL REGULATIONS - These general conditions, unless otherwise agreed in writing, govern all sales contracts concluded with the Seller and concerning the products included in its catalogues. These conditions, affixed to all the catalogues of the Seller with the list and the prices of the goods, are understood to be known by the buyers, and therefore effective against them when they view the catalog. Any derogation from these general conditions, even if made at the initiative of the Seller's agents, will be binding on the Seller only after its possible acceptance in writing and in any case limited to the individual contract to which it refers.
- 3) - ORDER CONFIRMATION - The contract of sale will be completed with the receipt by the Buyer of the Seller's order confirmation. Offers made to customers by agents, brokers or other intermediaries and the order proposals submitted by them, will not bind the Seller until the express acceptance with the aforementioned order confirmation. This order confirmation will prevail over the text of the offer or acceptance and will be binding on the purchaser if he has not objected to its conformity in writing within two days of receipt of the order confirmation.
- 4) - DELIVERY - the goods shall be deemed to have been sold "ex works" and the delivery shall be deemed to have been affected in the Seller's premises ten days after notification of the arrangement; or Failing this, at the time of return to the carrier or at the time of signature of the consignment note from that moment all risks of the material shall be transferred to the Buyer. The Buyer must also bear the costs of storage and custody if the goods are deposited with third parties and are not picked up promptly: The delivery terms are intended to approximate: even those expressly declared peremptory are subject to the tolerances of use and are extended as a result of events not attributable to the Seller. All shipments for railways and trucks will be made in assigned receipt. Shipments by sea and by land concerning supplies abroad will be made according to the conditions chosen from time to time approved by the International Chamber of Commerce and subsequent changes ("Incoterms").
- 5) - PRICES ARE INTENDED EX WORKS - Taxes, duties and expenses of all kinds are to be paid by the Buyer. The goods for billing and related payments will be quantified on the basis of the actual quantity supplied. The Seller may change the prices of the material in the event of higher increases of 10% in labor and raw materials between the purchase of the order and delivery. The only place of payment is the Seller's office, which has the right to accept bills of exchange, bank cheques, drafts authorizations without this involving the novation of the original credit, prejudice to the confidentiality agreement, change in the derogation from territorial jurisdiction. No payments shall be made to Agents, Representatives, or other persons other than the Seller, unless expressly waived in writing by the Seller on a case-by-case basis. Any delay or irregularity in payments shall entitle the Seller to terminate existing contracts or to suspend their delivery or to demand payment in advance, with immediate forfeiture of the benefit of the time limit, even if the contracts are different, as well as the right to compensation for any damages without any right for the Buyer to make claims for compensation or otherwise. The delay in payments, even partial, with respect to the terms of the contract or, failing that, the legal terms referred to in art. 4 of Legislative Decree 231/2002, will automatically run, without the need for late construction, the interest of the measure provided for in art. 5, paragraph 1 and 2, of DLGS 231/2002. It will also be due to the seller the reimbursement of the costs of recovery of sums not paid in time as required by art. 6 of the same decree according to the forensic fees in extrajudicial matters. If the sums are recovered in court, Articles. 633 and following of the c.p.c. according to the changes made by Legislative Decree 231/2002.
- 6) - GUARANTEE - The Seller provides the guarantee only for the material of first choice with a tolerance of 5%; the guarantee for the second and third choice and for the stocks is expressly excluded. The possible differences in shades and the desired imperfections of the decorations are a characteristic and a value of the artistic production, also the presence of cracks (craquelé) on the glazed surface is a phenomenon of artistic ceramics and tends to be less evident with adequate cleaning. Defects and defects of the goods must be reported in accordance with the law and, if found and recognized by the Seller, they will be entitled to replacement of the material. It is excluded the possibility of requiring the termination of the contract and compensation for direct or indirect damages due to the lack of availability of the material during the period necessary for its replacement. The buyer is responsible for the costs of transport, insurance and assembly of the material sent in replacement. The Seller remains the property of the replaced material which must be returned to its premises within thirty days of the shipment of the new material. The goods that have already been laid and the goods that have been treated with acid-based and therefore not adequate solutions are excluded from this warranty. The warranty regarding the use that will be made is always excluded, even if the Seller has provided opinions or suggestions.
- 7) - CHARACTERISTICS OF THE MATERIAL - The color of the material, the thickness, the shape and the settings created and forming part of brochures, price lists and other advertising material, are for illustrative purposes only and are purely indicative; are not binding on the Seller, which reserves the right to modify them at any time according to its commercial and production needs. Concerning laying and cleaning of our products, please refer to the instructions contained in this catalogue, which are intended to be binding for their correct maintenance and installation.
- 8) - PROHIBITION OF ACTION - The Purchaser cannot delay or suspend payments for any reason, even in the event of disputes or complaints, nor can he bring legal proceedings against the Seller if he has not previously settled the debt in full.
- 9) - RETENTION OF TITLE AGREEMENT - In case of sale and deferred payment, the Seller remains the owner of the material until the full payment of the debt by the buyer.
- 10) - CONTRACTUAL CHANGES - Any changes to these general conditions must be made in writing or confirmed by registered letter from the Seller.
- 11) - THE RESOLUTION OF DISPUTES - It is delegated to the jurisdiction of the Judicial Authority of Modena, without prejudice to the faculty of the seller to appeal to the Judicial Authority of the place of residence or domicile of the Buyer. In case of supplies abroad, any disputes that may arise will be regulated by Italian law.
- 12) - TREATMENT OF PERSONAL DATA - Pursuant to art. 10 of the law of 31 December 1996 number 675, the Seller informs the Buyer that the personal data provided by the Seller, or otherwise acquired by the Seller in the course of its activities also with companies offering commercial information services, may be processed, in compliance with the aforementioned legislation and the obligations of confidentiality to which the Seller is bound. The processing of personal data is their collection, registration, organization, storage, processing, modification, selection, extraction, comparison, use, interconnection, blocking, communication, dissemination, cancellation and destruction or the combination of two or more such operations. The data in question will be processed for purposes related to the activities of the Seller. In relation to the aforementioned processing, the Buyer may exercise the rights referred to in Article 13 of Law 675/96. The provision of data, although not mandatory, is however necessary as strictly functional to the performance of the contracts governed by these general conditions of sale for which the lack of consent from the Buyer's part to the processing of data will entail, where unavoidable for the quality of the data whose processing or consent to communication is denied, the termination of the contracts or the impossibility of giving effect to them. The owner of the aforementioned treatments is Ceramiche Grazia S.p.A. with registered and administrative headquarter in Formigine (MO) Italy in the person of the legal representative for the purposes of Law 675/96.

Consigli di posa gres porcellanato

Gentile Cliente,

il gres porcellanato Grazia è un gres a tutto impasto R10, superficie nata per garantire la massima prestazione tecnica e per l'utilizzo sia domestico che commerciale. Per mantenere sempre al meglio il materiale, consigliamo di procedere effettuando fin da subito una corretta pulizia dopo posa e una corretta manutenzione.

A tal proposito, consigliamo di:

- Effettuare la pulizia contestuale alla posa usando **FILA INSTANT REMOVER** (in caso di stucco cementizio). Consiglio dell'esperto: si raccomanda di evitare l'impiego di stucchi a contrasto; qualora vengano utilizzati, è indispensabile rimuovere accuratamente lo stucco fresco durante la posa e procedere con una pulizia di fine cantiere scrupolosa, evitando la ridistribuzione del materiale residuo sulla superficie in fase di lavaggio.
- A stucco indurito, procedere effettuando la pulizia di fine cantiere usando un detergente acido tamponato come **DETERDEK PRO**. Qualora si usi stucco epossidico, usare un detergente alcalino specifico come **CR10**.
- Per mantenere il pavimento al meglio, effettuare la pulizia ordinaria con prodotti neutri che non lascino residui, come **CLEANER PRO** da usarsi opportunamente diluito.
- In caso si abbia la necessità di effettuare una pulizia straordinaria, impiegare detergenti alcalini specifici come **PS87 PRO**.

Consigli di posa e protezione prodotti con smalto craquelé

Sui supporti in smalto Craquelé, si consiglia di procedere:

- Effettuando un trattamento pre – posa impiegando **MP90**; il prodotto permette di agevolare la pulizia di fine cantiere senza modificare l'aspetto della superficie. Non è un prodotto filmante.
- Effettuare una corretta pulizia contestuale alla posa usando acqua e prodotti a pH Neutro, avendo cura di rimuovere quanto più stucco possibile in fase di installazione. Consiglio dell'esperto: evitare l'uso di stucchi a contrasto.
- Effettuare la pulizia di fine cantiere usando prodotti a pH neutro come **CLEANER PRO** diluito 1:30
- Se necessario, applicare una leggera mano di protettivo idro – oleorepellente a rinforzo del precedente pretrattamento. Per questa operazione è possibile usare **MP90** o **MP90ECO XTREME**.
- Effettuare la pulizia ordinaria con prodotti neutri come **CLEAN&SHINE** o **CLEANER PRO** diluito 1:200.
- Evitare l'uso di sostanze acide o prodotti fortemente alcalini o abrasivi.
- Testare sempre i prodotti prima dell'uso.

Porcelain stoneware installation tips

Dear Customer,

Grazia porcelain stoneware is an R10 full-body stoneware, a surface created to guarantee maximum technical performance and for both domestic and commercial use. To always keep the material at its best, we recommend proceeding by immediately carrying out correct cleaning after installation and correct maintenance.

We recommend:

- *Carry out cleaning at the installation using **FILA INSTANT REMOVER** (in case of cement filler). Expert advice: it is recommended to avoid the use of contrasting fillers; if they are used, it is essential to carefully remove the fresh filler during installation and proceed with scrupulous end-of-construction cleaning, avoiding the redistribution of residual material on the surface during washing.*
- *Once the filler will be dry, proceed by cleaning using a buffered acid detergent such as **DETERDEK PRO**. If using epoxy filler, use a specific alkaline cleaner such as **CR10**.*
- *To keep the floor as best as possible, carry out ordinary cleaning with neutral products that leave no residue, such as **CLEANER PRO** to be used appropriately diluted.*
- *If you need to carry out an extraordinary cleaning, use specific alkaline detergents such as **PS87 PRO**.*

Installation and protection tips products with craquelé glaze

On Craquelé glaze supports, we recommend proceeding:

- *By carrying out a pre-installation treatment using **MP90**; the product allows you to facilitate end-of-construction cleaning without changing the appearance of the surface. It is not a filming product.*
- *Carry out correct cleaning at the same time as installation using water and pH Neutral products, taking care to remove as much putty as possible during installation. Expert tip: Avoid using contrasting putties.*
- *Carry out end-of-construction cleaning using neutral pH products such as **CLEANER PRO** diluted 1:30*
- *If necessary, apply a light coat of hydro – oleophobic protective agent to reinforce the previous pretreatment. For this operation you can use **MP90** or **MP90ECO XTREME**.*
- *Carry out ordinary cleaning with neutral products such as **CLEAN&SHINE** or **CLEANER PRO** diluted 1:200.*
- *Avoid using acidic substances or strongly alkaline or abrasive products.*
- *Always test products before use.*

CERAMICHE GRAZIA spa
GENERAL BOOK
settembre 2025

Ceramiche Grazia s.p.a.
via Radici in Piano, 71 - 41043 Corlo (Modena) Italy tel. 059.740.0611 - info@ceramichegrazia.it - www.ceramichegrazia.it

Progetto grafico: Creo Design&Consulting - creodesignconsulting.it
Stampa: Artestampa Fioranese - artestampafioranese.com

L'uso del marchio o la riproduzione del contenuto di questo catalogo è protetto dalla legge sulla proprietà intellettuale.
Qualsiasi uso del suddetto o la sua riproduzione, totale o parziale, deve essere autorizzato da Ceramiche Grazia spa.

Ceramiche Grazia si riserva il diritto di modificare e/o sospendere alcuni modelli presenti in questo catalogo.
Il colore dei pezzi qui visualizzati potrebbe differire leggermente dagli originali.
Le ambientazioni mostrate in questo catalogo sono proposte di design a scopo pubblicitario.
Nelle situazioni reali in cui i pezzi vengono posati, devono essere seguite le istruzioni di posa pubblicate da Ceramiche Grazia.

*Ceramiche Grazia reserves the right to modify and/or discontinue certain models displayed in this catalogue.
The colour of the pieces displayed herein may differ slightly from originals.
The settings shown in this catalogue are design proposals for advertising purposes.
In real situations in which the pieces are laid, the installation instructions published by Ceramiche Grazia should be followed.*

CERAMICHE

GRAZIA

SINCE 1970

Ceramiche Grazia S.p.A
Via Radici in Piano, 71
41043 Corlo (MO)

+39 059 7400611
info@ceramichegrazia.it